

PROPOSED INTERIOR WORK OF "SAI BABA EDUCATIONAL CAMPUS" AT GAT NO. : 183, NIMGAON KORHALE, TAL. : RAHATA, DIST. : AHMEDNAGAR. FOR SHRI SAI BABA SANSTHAN TRUST SHIRDI.					
FURNITURE WORK BOQ					
Sr. No	Description	Qty	Unit	Rate	Amount
	Staff Working Area				
1	Cubicles: Plywood structure of 18mm, 12mm & 6mm thicknesses as indicated. Finishing on both side with specified laminates. Drawers to contain side mounting & Telescopic channels of approved make. Shutters (19mm Blockboard) to contain sliding fittings of approved make. PVC Edge band / laminate of matching colour. 12mm Soft board to be provided with specified fabric wrapped all around. Teak Wood to be used for Lipping & Meranti Wood for Partition. Please refer to drawing for other details and specifications.	75	Nos.		
2	File Storage Units : Plywood structure of 18mm, 12mm & 6mm thicknesses as indicated. Finishing on both side with specified laminates. Drawers to contain side mounting & Telescopic channels of approved make. Shutters (19mm Blockboard) to contain appropriate hinges of approved make. PVC Edge band / laminate of matching colour. 12mm Soft board to be provided with specified fabric wrapped all around. Teak Wood to be used for Lipping & Meranti Wood for Partition. Please refer to drawing for other details and specifications.	77.92	Sq.M.		
3	Admin (Cashier) File Cabinet : Marine Plywood structure of 18mm, 12mm thicknesses as indicated. Finishing on both side with specified laminates. Drawers to contain side mounting & Telescopic channels of approved make. Shutters (19mm Blockboard) to contain appropriate hinges of approved make. Edge binding tape/ laminate of matching colour. Shelves to be made in 19mm Blockboard with laminate on both sides. Teak Wood to be used for Lipping. 18mm Granite to be mounted on Plywood on Counter Top. Please refer to drawing for other details and specifications.	37.04	Sq.M.		
4	Admin Internal Partition : Plywood structure of 12mm thicknesses as indicated with Meranti/Plywood Framing. Finishing on both side with specified laminates. 12 mm Toughened glass to be used wherever mentioned Please refer to drawing for other details and specifications. Doors to provided with concealed door closers.	68.22	Sq.M.		
5	Staff Area Internal Partition: Plywood structure of 12mm thicknesses as indicated with Meranti/Plywood Framing. Finishing on both side with specified laminates. 12 mm Toughened glass to be used wherever mentioned Please refer to drawing for other details and specifications.	159.82	Sq.M.		
6	Cubicle + Admin Chairs : Model: Blake Study Chair (Urban Ladder)	87	Nos.		
7	Pantry Console: Marine Plywood structure of 18mm, 12mm thicknesses as indicated. Finishing on both side with specified laminates. Drawers to contain side mounting & Telescopic channels of approved make. Shutters (19mm Blockboard) to contain appropriate hinges of approved make. Edge binding tape/ laminate of matching colour. Shelves to be made in 19mm Blockboard with laminate on both sides. Teak Wood to be used for Lipping. 18mm Granite to be mounted on Plywood on Counter Top. Please refer to drawing for other details and specifications.	8.1	Sq.M.		

Sr. No	Description	Qty	Unit	Rate	Amount
8	Staff Table: Plywood structure of 18mm, 12mm & 6mm thicknesses as indicated. Finishing on both side with specified laminates. Drawers to contain side mounting & Telescopic channels of approved make. Shutters (19mm Blockboard) to contain appropriate hinges of approved make. PVC Edge band / laminate of matching colour. 12mm Soft board to be provided with specified fabric wrapped all around. Teak Wood to be used for Lipping & Meranti Wood for Partition. Please refer to drawing for other details and specifications.	1	Nos.		
9	Manager's Table /Asst. Manager's Table: Plywood structure of 18mm, 12mm & 6mm thicknesses as indicated. Finishing on External side with specified veneer & laminates on internal sides. Drawers to contain side mounting & Telescopic channels of approved make. Shutters (19mm Blockboard) to contain appropriate hinges of approved make. Veneer to be applied on all edges of drawers & shutters. First Grade Teak Wood to be used for the stand with appropriate wooden joinery. Cable managers & Switch Boards to be placed as per user's requirements. Please refer to drawing for other details and specifications.	2	Nos.		
	Waiting Lounge				
10	Benches at Periphery: Tendam seating MetXtro Sunstar Three Seater (Amazon)	28	Nos.		
	Principal's / Voice Principal Cabin with Anti Chamber				
11	Principal's/ Voice Principal Table: Plywood structure of 18mm, 12mm & 6mm thicknesses as indicated. Finishing on External side with specified veneer & laminates on internal sides. Drawers to contain side mounting & Telescopic channels of approved make. Shutters (19mm Blockboard) to contain appropriate hinges of approved make. Veneer to be applied on all edges of drawers & shutters. First Grade Teak Wood to be used for the stand with appropriate wooden joinery. Cable managers & Switch Boards to be placed as per user's requirements. Please refer to drawing for other details and specifications.	6	Nos.		
12	Conference Table: Plywood structure of 18mm, 12mm & 6mm thicknesses as indicated. Finishing on External side with specified veneer & laminates on internal sides. First Grade Teak Wood to be used for the table top border with appropriate wooden joinery. Cable managers & Switch Boards to be placed as per user's requirements. Adequate framing to be done for Pedestal to ensure strength. Please refer to drawing for other details and specifications.	6	Nos.		
13	Back Runner (File Storage): Plywood structure of 18mm, 12mm thicknesses as indicated. Finishing on both side with specified laminates. Drawers to contain side mounting & Telescopic channels of approved make. Shutters (19mm Blockboard) to contain appropriate hinges of approved make. PVC Edge band/ laminate of matching colour. Shelves to be made in 19mm Blockboard with laminate on both sides. Teak Wood to be used for Lipping. Please refer to drawing for other details and specifications.	43.12	Sq.M.		
14	Library Unit: Plywood structure of 18mm, 12mm thicknesses as indicated. Finishing on both side with specified laminates. Drawers to contain side mounting & Telescopic channels of approved make. Shutters (19mm Blockboard) to contain appropriate hinges of approved make. PVC Edge band/ laminate of matching colour. Shelves to be made in 19mm Blockboard with laminate on both sides. Teak Wood to be used for Lipping. Please refer to drawing for other details and specifications.	15.04	Sq.M.		

Sr. No	Description	Qty	Unit	Rate	Amount
15	Conference Console: Plywood structure of 18mm, 12mm thicknesses as indicated. Finishing on both side with specified laminates. Drawers to contain side mounting & Telescopic channels of approved make. Shutters (19mm Blockboard) to contain appropriate hinges of approved make. PVC Edge band/ laminate of matching colour. Shelves to be made in 19mm Blockboard with laminate on both sides. Teak Wood to be used for Lipping. Please refer to drawing for other details and specifications.	4.8	Sq.M.		
16	Artefact Console (Anti - Chamber): Plywood structure of 18mm, 12mm thicknesses as indicated. Finishing on both side with specified laminates. Drawers to contain side mounting & Telescopic channels of approved make. Shutters (19mm Blockboard) to contain appropriate hinges of approved make. PVC Edge band/ laminate of matching colour. Shelves to be made in 19mm Blockboard with laminate on both sides. Teak Wood to be used for Lipping. Please refer to drawing for other details and specifications.	2.48	Sq.M.		
17	TV Unit (Anti - Chamber): Plywood structure of 18mm, 12mm & 6mm thicknesses as indicated. Finishing on both side with specified laminates. Drawers to contain side mounting & Telescopic channels of approved make. Shutters (19mm Blockboard) to contain sliding fittings of approved make. PVC Edge band / laminate of matching colour. Teak Wood to be used for Lipping & Meranti Wood for Partition. Cable managers & Switch Boards to be placed as per electrical layout. Please refer to drawing for other details and specifications.	17.12	Sq.M.		
18	Pantry Console: Marine Plywood structure of 18mm, 12mm thicknesses as indicated. Finishing on both side with specified laminates. Drawers to contain side mounting & Telescopic channels of approved make. Shutters (19mm Blockboard) to contain appropriate hinges of approved make. Edge binding tape/ laminate of matching colour. Shelves to be made in 19mm Blockboard with laminate on both sides. Teak Wood to be used for Lipping. 18mm Granite to be mounted on Plywood on Counter Top. Please refer to drawing for other details and specifications.	11.72	Sq.M.		
19	Partition Wall + Door: Plywood structure of 12mm thicknesses as indicated with Meranti/Plywood Framing. Finishing on both side with specified laminates. 12 mm Toughened glass to be used wherever mentioned Please refer to drawing for other details and specifications. Doors to provided with concealed door closers.	36.9	Sq.M.		
20	Principal's Chair / Voice principal/Manager's Chair: Model: Liberate High Back (Featherlite)	9	Nos.		
21	Visitor's Chair: Model: Optima Mid Back Visitor Chair (Nilkamal)	54	Nos.		
22	Conference Chair: Model: Blake Study Chair (Urban Ladder)	72	Nos.		
23	Centre Table : Model: Galatea Marble Coffee Table (Urban Ladder)	14	Nos.		
24	Side Table Model: Galatea Marble Side Table (Urban Ladder)	29	Nos.		
25	3 Seater Sofa: Upholstered with a Premium quality fabric & Cushioning. Framing in good quality Teakwood wood & Plywood. Legs/Stand in Teakwood with melamine polish. Seat, backrest and armrests - padded with polyurethane foam and upholstered in beige and/or light grey woven fabric. Frame of sofas made of durable wood and the base of seat and backrest equipped with metal Z-shape springs.	16	Nos.		
26	Sofa Chairs : Upholstered with a Premium quality fabric & Cushioning. Framing in good quality Teakwood wood & Plywood. Legs/Stand in Teakwood with melamine polish. Seat, backrest and armrests - padded with polyurethane foam and upholstered in beige and/or light grey woven fabric. Frame of sofas made of durable wood and the base of seat and backrest equipped with metal Z-shape springs.	41	Nos.		

Sr. No	Description	Qty	Unit	Rate	Amount
27	4 Seater Sofa (Anti Chamber) : Upholstered with a Premium quality fabric & Cushioning. Framing in good quality Teakwood wood & Plywood. Legs/Stand in Teakwood with melamine polish. Seat, backrest and armrests - padded with polyurethane foam and upholstered in beige and/or light grey woven fabric. Frame of sofas made of durable wood and the base of seat and backrest equipped with metal Z-shape springs.	4	Nos.		
	Staff Room				
28	Cubicles: Plywood structure of 18mm, 12mm & 6mm thicknesses as indicated. Finishing on both side with specified laminates. Drawers to contain side mounting & Telescopic channels of approved make. Shutters (19mm Blockboard) to contain sliding fittings of approved make. PVC Edge band / laminate of matching colour. 12mm Soft board to be provided with specified fabric wrapped all around. Teak Wood to be used for Lipping & Meranti Wood for Partition. Please refer to drawing for other details and specifications.	56	Nos.		
29	Conference Table: 14 Gauge MS Box Section structure of 30x30mm size for legs/frame & 40x40mm size for Base tie members as indicated. Finishing on External side with specified laminates on both sides. First Grade Teak Wood to used for the table top border with appropriate wooden joinery. Levelers to be provided at the bottom. Please refer to drawing for other details and specifications.	2	Nos.		
30	File Storage Units: Plywood structure of 18mm, 12mm thicknesses as indicated. Finishing on both side with specified laminates. Drawers to contain side mounting & Telescopic channels of approved make. Shutters (19mm Blockboard) to contain appropriate hinges of approved make. PVC Edge band/ laminate of matching colour. Shelves to be made in 19mm Blockboard with laminate on both sides. Teak Wood to be used for Lipping. Please refer to drawing for other details and specifications.	24.54	Sq.M.		
31	Cubicle Chairs: Model: Blake Study Chair (Urban Ladder)	56	Nos.		
32	Conference Chairs: Model: Blake Study Chair (Urban Ladder)	16	Nos.		
	Staff Room				
33	Cubicles: Plywood structure of 18mm, 12mm & 6mm thicknesses as indicated. Finishing on both side with specified laminates. Drawers to contain side mounting & Telescopic channels of approved make. Shutters (19mm Blockboard) to contain sliding fittings of approved make. PVC Edge band / laminate of matching colour. 12mm Soft board to be provided with specified fabric wrapped all around. Teak Wood to be used for Lipping & Meranti Wood for Partition. Please refer to drawing for other details and specifications.	210	Nos.		
34	File Storage Unit: Plywood structure of 18mm, 12mm thicknesses as indicated. Finishing on both side with specified laminates. Drawers to contain side mounting & Telescopic channels of approved make. Shutters (19mm Blockboard) to contain appropriate hinges of approved make. PVC Edge band/ laminate of matching colour. Shelves to be made in 19mm Blockboard with laminate on both sides. Teak Wood to be used for Lipping. Please refer to drawing for other details and specifications.	111.06	Sq.M.		
35	Cubicle Chairs: Model: Blake Study Chair (Urban Ladder)	210	Nos.		
	Library				
36	Stacking Units : Godrej Library Racks	486	Nos.		

Sr. No	Description	Qty	Unit	Rate	Amount
37	Issuing File Storage : Plywood structure of 18mm, 12mm thicknesses as indicated. Finishing on both side with specified laminates. Drawers to contain side mounting & Telescopic channels of approved make. Shutters (19mm Blockboard) to contain appropriate hinges of approved make. PVC Edge band/ laminate of matching colour. Shelves to be made in 19mm Blockboard with laminate on both sides. Teak Wood to be used for Lipping. Please refer to drawing for other details and specifications.	12.33	Sq.M.		
38	Librarian's Back Runner : Plywood structure of 18mm, 12mm thicknesses as indicated. Finishing on both side with specified laminates. Drawers to contain side mounting & Telescopic channels of approved make. Shutters (19mm Blockboard) to contain appropriate hinges of approved make. PVC Edge band/ laminate of matching colour. Shelves to be made in 19mm Blockboard with laminate on both sides. Teak Wood to be used for Lipping. Please refer to drawing for other details and specifications.	9.76	Sq.M.		
39	Xerox Room File Storage: Plywood structure of 18mm, 12mm thicknesses as indicated. Finishing on both side with specified laminates. Drawers to contain side mounting & Telescopic channels of approved make. Shutters (19mm Blockboard) to contain appropriate hinges of approved make. PVC Edge band/ laminate of matching colour. Shelves to be made in 19mm Blockboard with laminate on both sides. Teak Wood to be used for Lipping. Please refer to drawing for other details and specifications.	8.84	Sq.M.		
40	Issuing Counters : Plywood structure of 18mm, 12mm & 6mm thicknesses as indicated. Finishing on External side with specified veneer & laminates on internal sides. Drawers to contain side mounting & Telescopic channels of approved make. Shutters (19mm Blockboard) to contain appropriate hinges of approved make. Veneer to be applied on all edges of drawers & shutters. 12mm Soft board to be provided with specified fabric wrapped all around. Cable managers & Switch Boards to be placed as per user's requirements. Please refer to drawing for other details and specifications.	6	Nos.		
41	Librarian's Office table: Plywood structure of 18mm, 12mm & 6mm thicknesses as indicated. Finishing on External side with specified veneer & laminates on internal sides. Drawers to contain side mounting & Telescopic channels of approved make. Shutters (19mm Blockboard) to contain appropriate hinges of approved make. Veneer to be applied on all edges of drawers & shutters. First Grade Teak Wood to used for the stand with appropriate wooden joinery. Cable managers & Switch Boards to be placed as per user's requirements. Please refer to drawing for other details and specifications.	3	Nos.		
42	Reading Tables : 14 Gauge MS Box Section structure of 30x30mm size for legs/frame & 40x40mm size for Base tie members as indicated. Finishing on External side with specified laminates on both sides. First Grade Teak Wood to used for the table top border with appropriate wooden joinery. Levelers to be provided at the bottom. Please refer to drawing for other details and specifications.	43	Nos.		
43	E Library Tables : 14 Gauge MS Box Section structure of 30x30mm size for legs/frame & 40x40mm size for Base tie members as indicated. Finishing on External side with specified laminates on both sides. First Grade Teak Wood to used for the table top border with appropriate wooden joinery. Levelers to be provided at the bottom. Please refer to drawing for other details and specifications.	50	Nos.		
44	Library Executive Chairs :Model: Blake Study Chair (Amazon)	15	Nos.		

Sr. No	Description	Qty	Unit	Rate	Amount
45	Reader's Chairs : Nilkamal Novella 08 Series	317	Nos.		
	Class Room				
46	Table : Plywood structure of 18mm, 12mm & 6mm thicknesses as indicated. Finishing on both side with specified laminates. Drawers to contain side mounting & Telescopic channels of approved make. Shutters (19mm Blockboard) to contain sliding fittings of approved make. PVC Edge band / laminate of matching colour. 12mm Soft board to be provided with specified fabric wrapped all around. Teak Wood to be used for Lipping & Meranti Wood for Partition. Please refer to drawing for other details and specifications.	134	Nos.		
47	Desk: Plywood structure of 18mm, 12mm thicknesses as indicated. Finishing with specified oil paint. Teak Wood to be used for Lipping. Please refer to drawing for other details and specifications.	402	Sq.M.		
48	Chairs: Model: Blake Study Chair	134	Nos.		
49	Bench: An integrated two-seater desk cum bench for classrooms. Key Features- Round top edges for safe use, Angled table top for comfort when writing, Structure is completely free from any sharp edges, Sturdy and robust construction for durability. Pre-laminated commercial board confirming to IS 12823 with pvc edge banding, Desk Table Size is 1200(W) x 400(D) x 18mm(T) - OSL commercial Board, Desk seat Size 1200(W) x 330(D) x 18mm(T) - OSL commercial Board, Height of desk is Front end 770mm User end 740mm , slant at 3 Degree, Height of seat is 440mm, Bench & Seat back angle is 7 Degrees, Seat Back Size 1200(W) x 170(D) x 18mm(T) - commercial Board , Shelf Size 1200(W) x 300(D) x 18mm(T) - commercial Board, Leg Oval Pipe 2 Nos. - 30.5 x 16 x 1.6mm Thick MS Pipe etc. complete [For 5th to 10 Standered]	2904	Nos.		
50	Bench : An integrated two-seater desk cum bench for classrooms. Key Features- Round top edges for safe use, Angled table top for comfort when writing, Structure is completely free from any sharp edges, Sturdy and robust construction for durability. Pre-laminated commercial board confirming to IS 12823 with pvc edge banding, [Bench For up to 4th Standered]	725	Nos.		
51	Drawer Console : Plywood structure of 18mm, 12mm thicknesses as indicated. Finishing on both side with specified laminates. Drawers to contain side mounting & Telescopic channels of approved make. Shutters (19mm Blockboard) to contain appropriate hinges of approved make. PVC Edge band/ laminate of matching colour. Shelves to be made in 19mm Blockboard with laminate on both sides. Teak Wood to be used for Lipping. Please refer to drawing for other details and specifications.	2.25	Sq.M.		
	Green Room				
52	Dressing Area (Window Side): Plywood structure of 18mm, 12mm thicknesses as indicated. Finishing on both side with specified laminates. Drawers to contain side mounting & Telescopic channels of approved make. Shutters (19mm Blockboard) to contain appropriate hinges of approved make. PVC Edge band/ laminate of matching colour. Shelves to be made in 19mm Blockboard with laminate on both sides. Teak Wood to be used for Lipping. Please refer to drawing for other details and specifications. 6mm Mirrors to be used with all sides CNC Polished. Installation of mirrors to ensure a Ply or PVC backing behind the mirrors.	32.4	Sq.M.		

Sr. No	Description	Qty	Unit	Rate	Amount
53	Wardrobe Unit: Plywood structure of 18mm, 12mm thicknesses as indicated. Finishing on both side with specified laminates. Drawers to contain side mounting & Telescopic channels of approved make. Shutters (19mm Blockboard) to contain appropriate hinges of approved make. PVC Edge band/ laminate of matching colour. Shelves to be made in 19mm Blockboard with laminate on both sides. Teak Wood to be used for Lipping. Please refer to drawing for other details and specifications.	25.38	Sq.M.		
54	Centre Table : Model: Galatea Marble Coffee Table (Urban Ladder)	6	Nos.		
55	Side Table: Model: Galatea Marble Side Table (Urban Ladder)	6	Nos.		
53	3 Seater Sofa : Upholstered with a Premium quality fabric & Cushioning. Framing in good quality Teakwood wood & Plywood. Legs/Stand in Teakwood with melamine polish. Seat, backrest and armrests - padded with polyurethane foam and upholstered in beige and/or light grey woven fabric. Frame of sofas made of durable wood and the base of seat and backrest equipped with metal Z-shape springs.	5	Nos.		
54	Sofa Chairs : Upholstered with a Premium quality fabric & Cushioning. Framing in good quality Teakwood wood & Plywood. Legs/Stand in Teakwood with melamine polish. Seat, backrest and armrests - padded with polyurethane foam and upholstered in beige and/or light grey woven fabric. Frame of sofas made of durable wood and the base of seat and backrest equipped with metal Z-shape springs.	4	Nos.		
55	Dressing Chairs : Model: Blake Study Chair (Urban Ladder)	18	Nos.		
	Baby Sitting Area				
56	Open Cabinet for books & Toys: Plywood structure of 18mm, 12mm thicknesses as indicated. Finishing on both side with specified laminates. Drawers to contain side mounting & Telescopic channels of approved make. Shutters (19mm Blockboard) to contain appropriate hinges of approved make. PVC Edge band/ laminate of matching colour. Shelves to be made in 19mm Blockboard with laminate on both sides. Teak Wood to be used for Lipping. Please refer to drawing for other details and specifications.	14.1	Sq.M.		
57	Single Bed with Mattress : Wooden Bed without storage. 6 Inches Mattress included.	4	Nos.		
58	Childrens study Tables : Plywood structure of 18mm, 12mm & 6mm thicknesses as indicated. Finishing on External side with specified veneer & laminates on internal sides. Drawers to contain side mounting & Telescopic channels of approved make. Shutters (19mm Blockboard) to contain appropriate hinges of approved make. Veneer to be applied on all edges of drawers & shutters. First Grade Teak Wood to be used for the stand with appropriate wooden joinery. Cable managers & Switch Boards to be placed as per user's requirements. Please refer to drawing for other details and specifications.	6	Nos.		
59	Centre Table : Model: Galatea Marble Coffee Table (Urban Ladder)	2			
55	Side Table Model: Galatea Marble Side Table (Urban Ladder)	6	Nos.		
53	3 Seater Sofa: Upholstered with a Premium quality fabric & Cushioning. Framing in good quality Teakwood wood & Plywood. Legs/Stand in Teakwood with melamine polish. Seat, backrest and armrests - padded with polyurethane foam and upholstered in beige and/or light grey woven fabric. Frame of sofas made of durable wood and the base of seat and backrest equipped with metal Z-shape springs.	2	Nos.		

Sr. No	Description	Qty	Unit	Rate	Amount
54	Sofa Chairs: Upholstered with a Premium quality fabric & Cushioning. Framing in good quality Teakwood wood & Plywood. Legs/Stand in Teakwood with melamine polish. Seat, backrest and armrests - padded with polyurethane foam and upholstered in beige and/or light grey woven fabric. Frame of sofas made of durable wood and the base of seat and backrest equipped with metal Z-shape springs.	8	Nos.		
	Guest Rooms				
55	Wardrobe : Plywood structure of 18mm, 12mm thicknesses as indicated. Finishing on both side with specified laminates. Drawers to contain side mounting & Telescopic channels of approved make. Shutters (19mm Blockboard) to contain appropriate hinges of approved make. PVC Edge band/ laminate of matching colour. Shelves to be made in 19mm Blockboard with laminate on both sides. Teak Wood to be used for Lipping. Please refer to drawing for other details and specifications.	50.76	Sq.M.		
56	Double Bed with Mattress : Wooden Bed without storage. 6 Inches Mattress included.	12	Nos.		
57	Study Table + Chair : Plywood structure of 18mm, 12mm & 6mm thicknesses as indicated. Finishing on External side with specified veneer & laminates on internal sides. Drawers to contain side mounting & Telescopic channels of approved make. Shutters (19mm Blockboard) to contain appropriate hinges of approved make. Veneer to be applied on all edges of drawers & shutters. First Grade Teak Wood to be used for the stand with appropriate wooden joinery. Cable managers & Switch Boards to be placed as per user's requirements. Please refer to drawing for other details and specifications.	12	Nos.		
58	Side Table : Model: Galatea Marble Side Table (Urban Ladder)	36	Nos.		
59	Sofa Chairs : Upholstered with a Premium quality fabric & Cushioning. Framing in good quality Teakwood wood & Plywood. Legs/Stand in Teakwood with melamine polish. Seat, backrest and armrests - padded with polyurethane foam and upholstered in beige and/or light grey woven fabric. Frame of sofas made of durable wood and the base of seat and backrest equipped with metal Z-shape springs.	12	Nos.		
60	Mild Steel Locker : Providing & Fixing Mild Steel Godrej locker as per detailed drawings.	160	Nos.		
61	Dining Table (1st to 4th std) : 6 seater Table with Powder coated MS Structure with inbuilt benches on both sides. Granite Top for table and bench both.	170	Nos.		
62	Dining Table (5th to 10th std) : 6 seater Table with Powder coated MS Structure with inbuilt benches on both sides. Granite Top for table and bench both.	600	Nos.		
TOTAL AMOUNT					

3 SEATER SOFA



SOFA CHAIR



PRINCIPAL'S CHAIR



PRINCIPAL'S CHAIR



VISITOR'S CHAIR



VISITORS BENCH



READER'S CHAIR IN LIBRARY

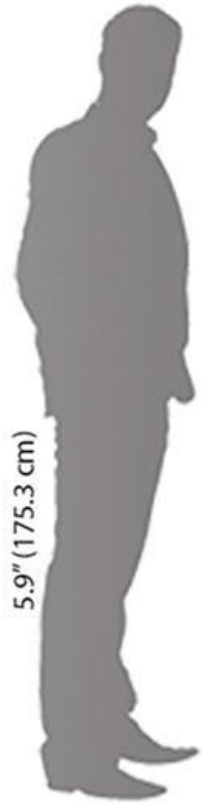

5.9" (175.3 cm)



Width
(46 cm)

Height
(81 cm)

Depth
(51 cm)



READER'S CHAIR IN LIBRARY



Library Storage Unit



CENTER TABLE



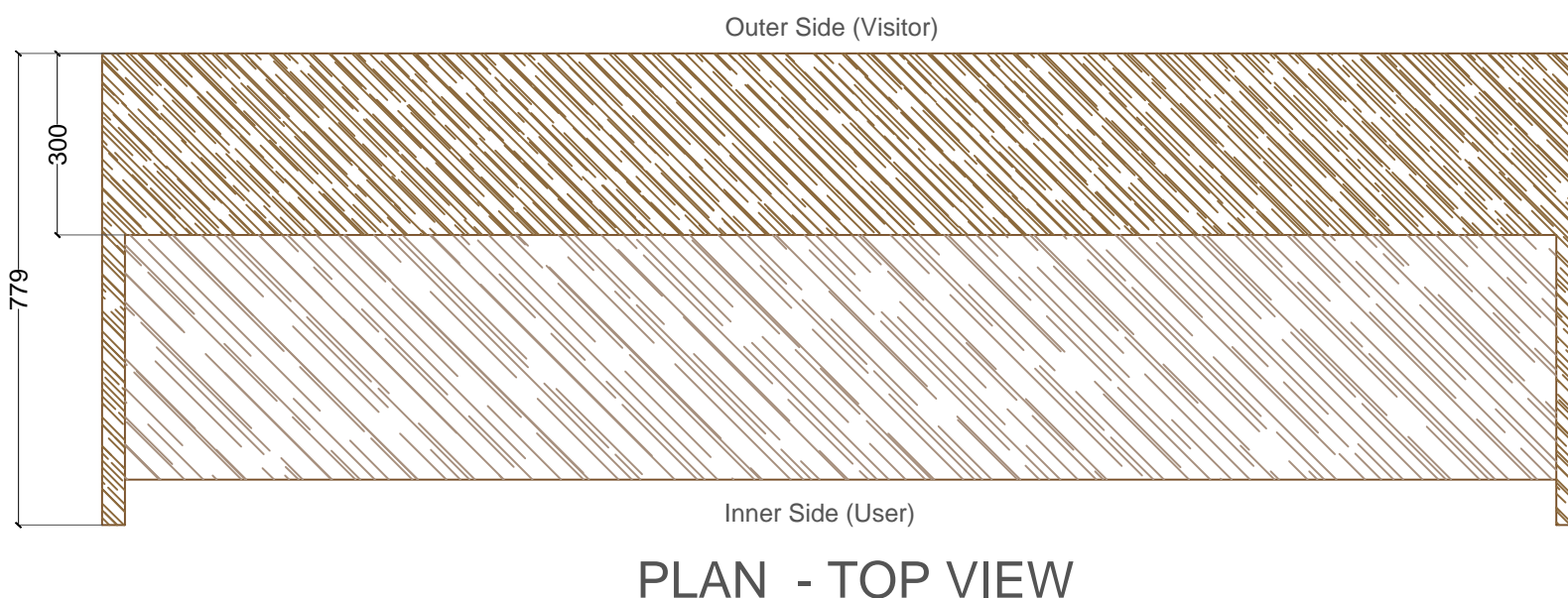
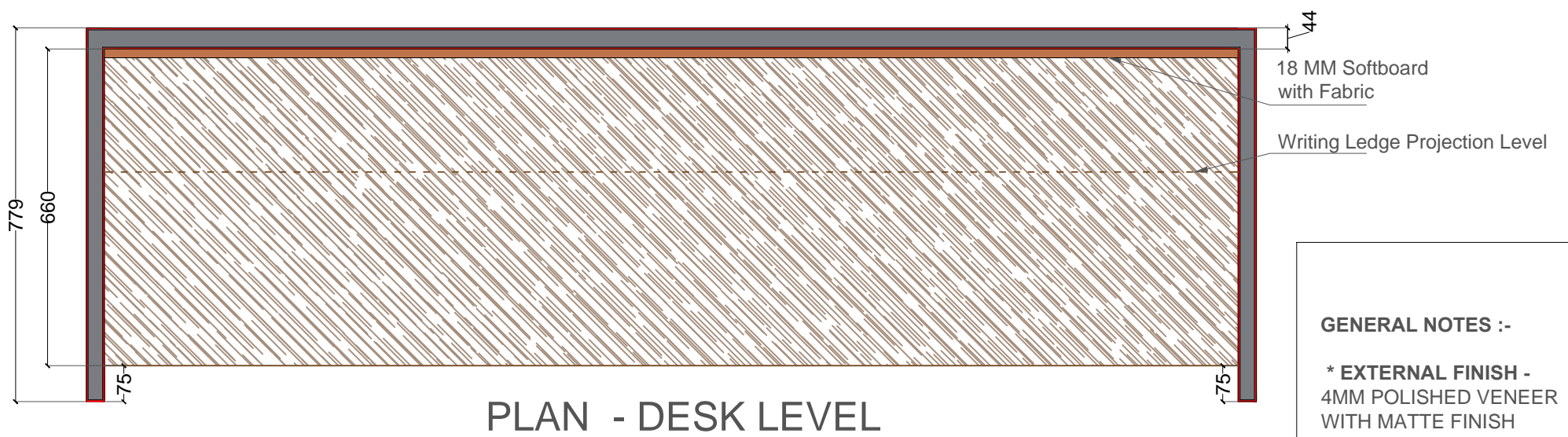
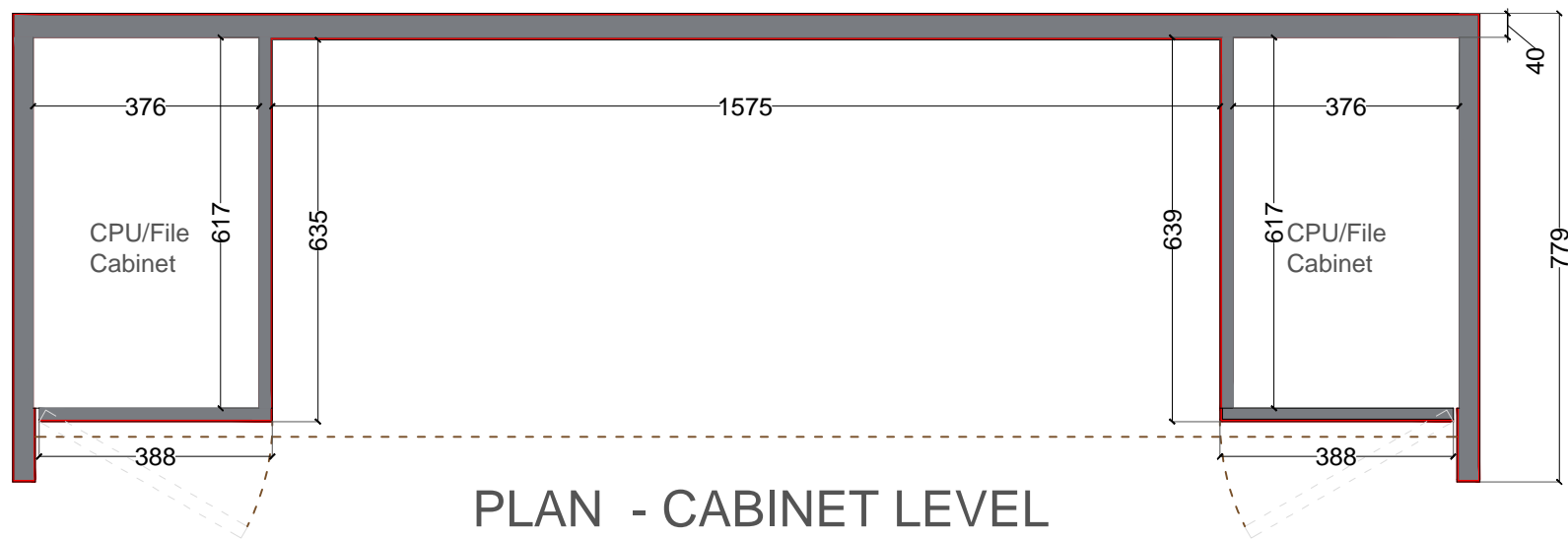
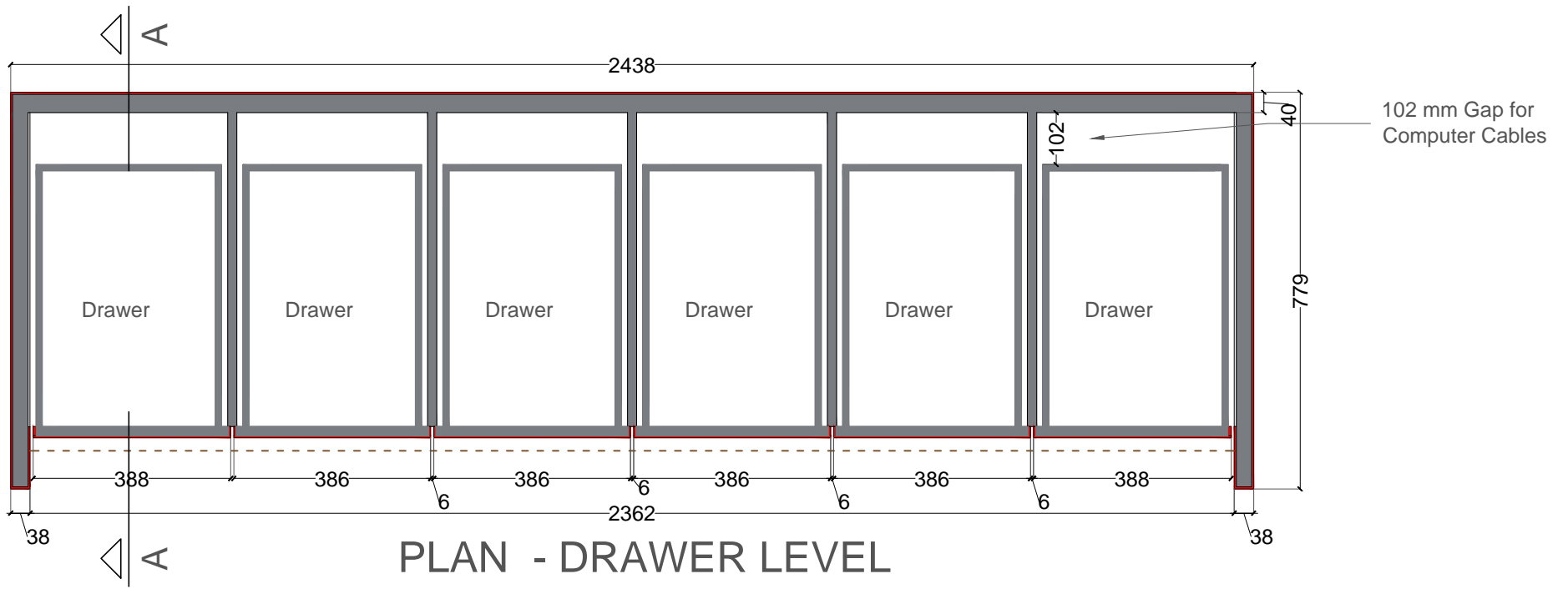

GENERAL NOTES :-

* **EXTERNAL FINISH** - 4MM POLISHED VENEER WITH MATTE FINISH MELAMINE POLISH

* **INTERNAL FINISH** - 0.8 MM LAMINATE AS PER SPECIFICATION

* Soft Close Telescopic Channels for Drawers

-  POLISHED VENEER
-  4 MM VENEER CUT SECTION
-  PLYWOOD CUT SECTION
-  LAMINATE SKIRTING
-  FABRIC

TABLE DETAILS - LIBRARY (ISSUING COUNTER)

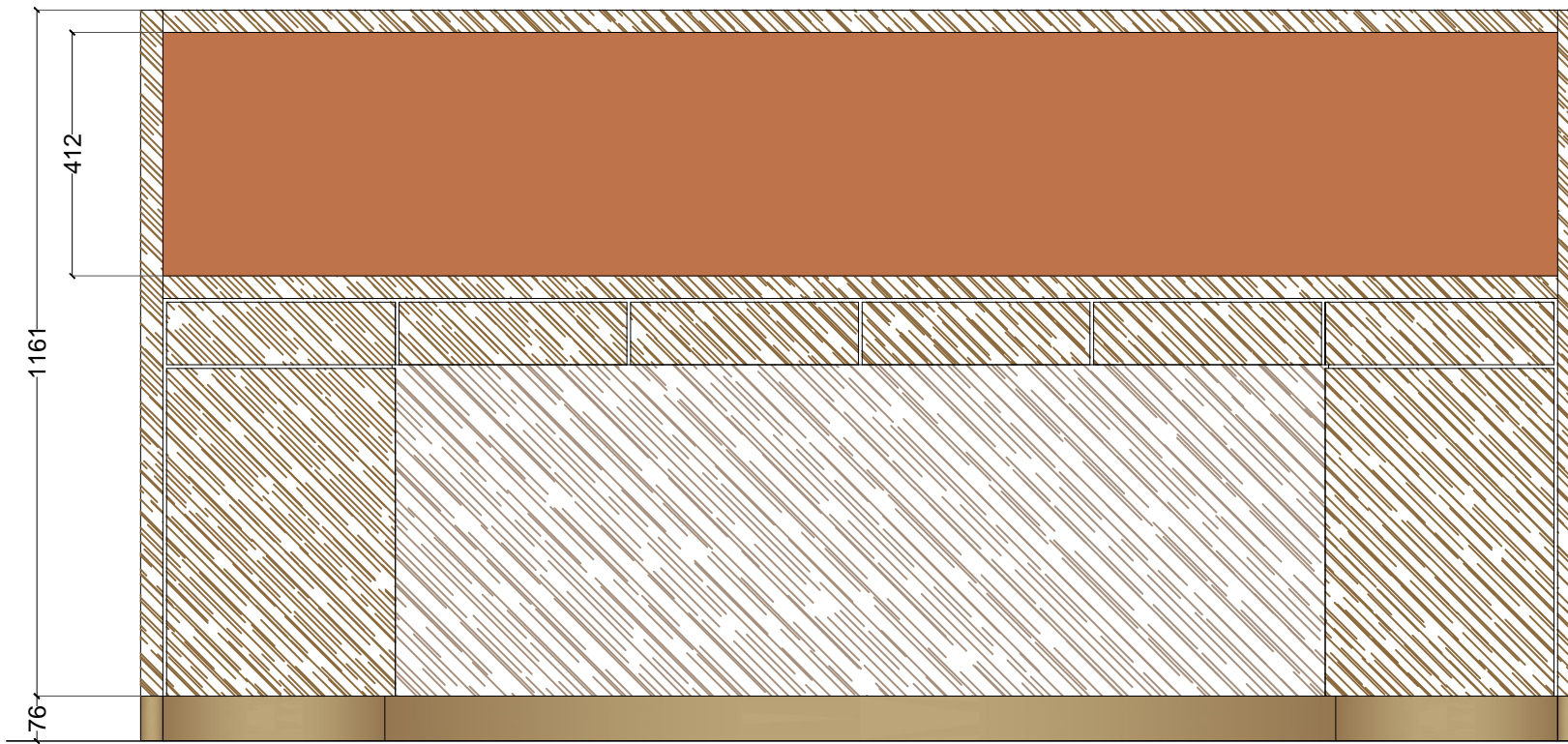

ELEVATION - In (User) Side

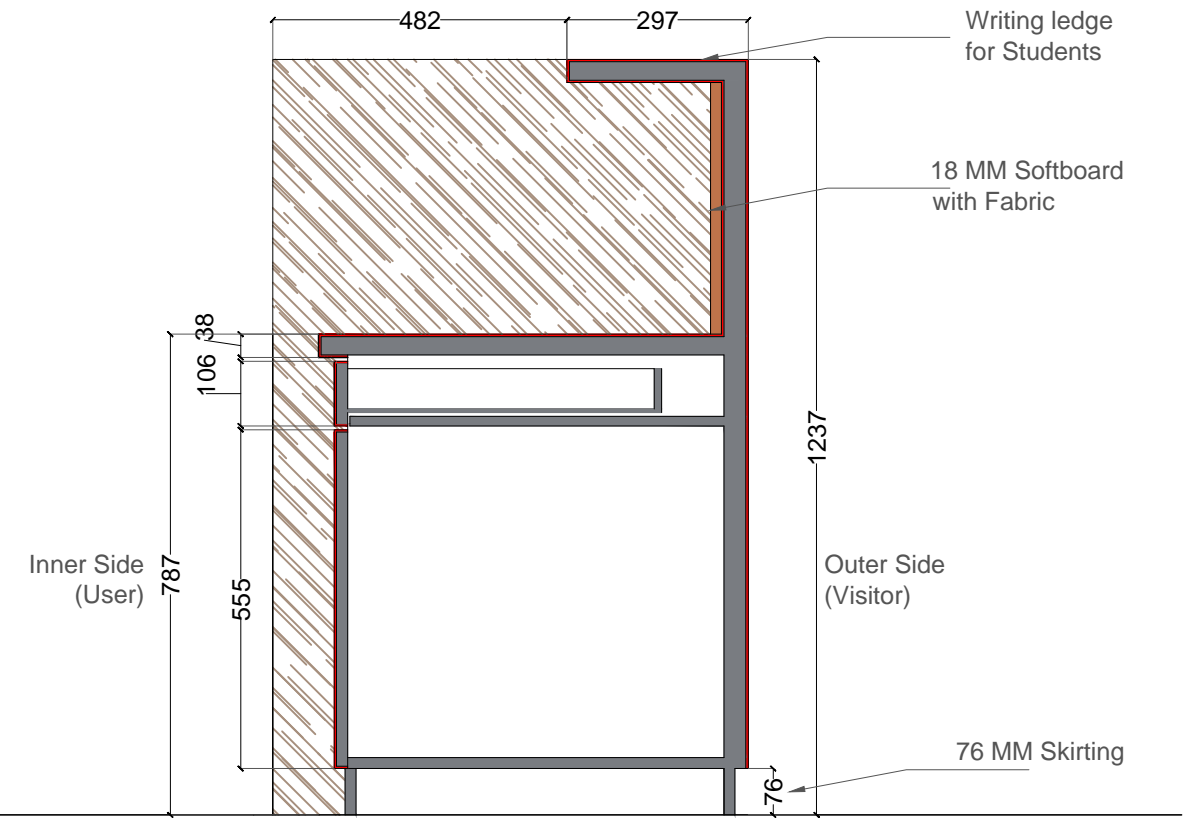

SECTION AA

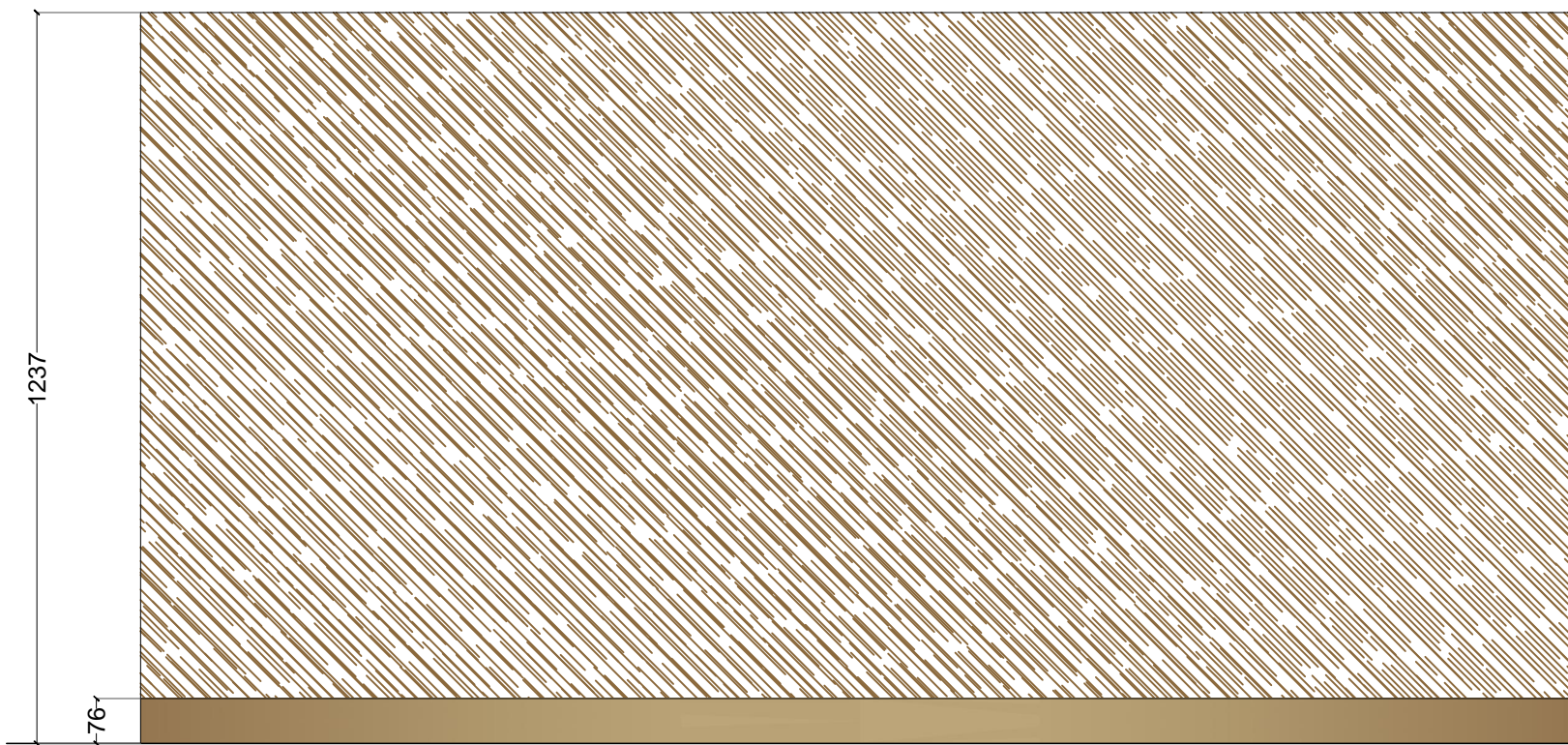

ELEVATION - Out (Visitor) Side

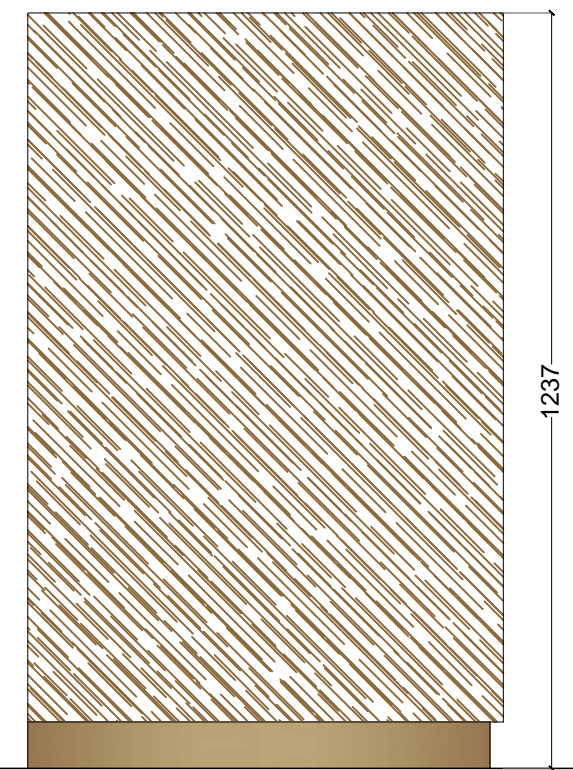

GENERAL NOTES :-

* **EXTERNAL FINISH -**
4MM POLISHED VENEER
WITH MATTE FINISH
MELAMINE POLISH

* **INTERNAL FINISH -**
0.8 MM LAMINATE AS PER
SPECIFICATION

* Soft Close Telescopic
Channels for Drawers

-  POLISHED VENEER
-  4 MM VENEER CUT SECTION
-  PLYWOOD CUT SECTION
-  LAMINATE SKIRTING
-  FABRIC

TABLE DETAILS - LIBRARY (ISSUING COUNTER)

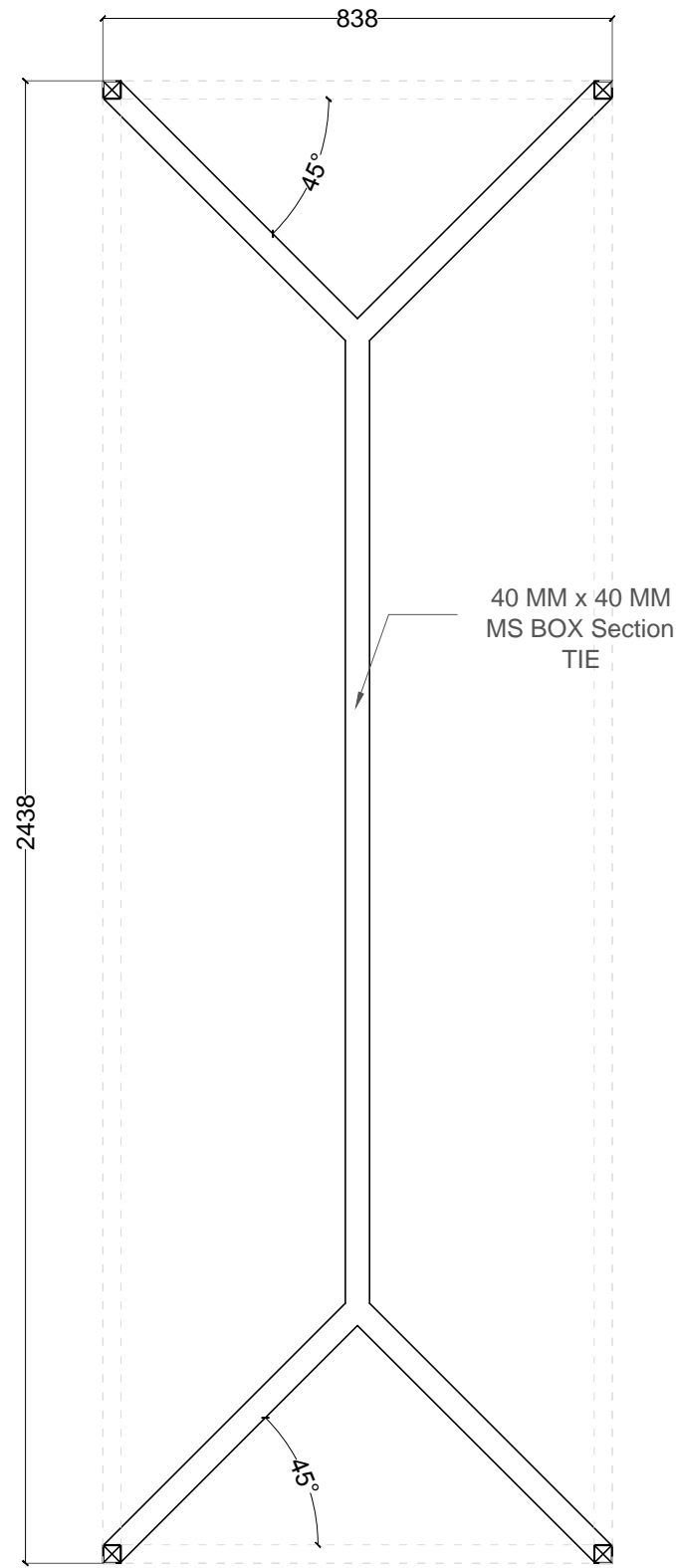

PLAN

BOTTOM TIE DETAILS

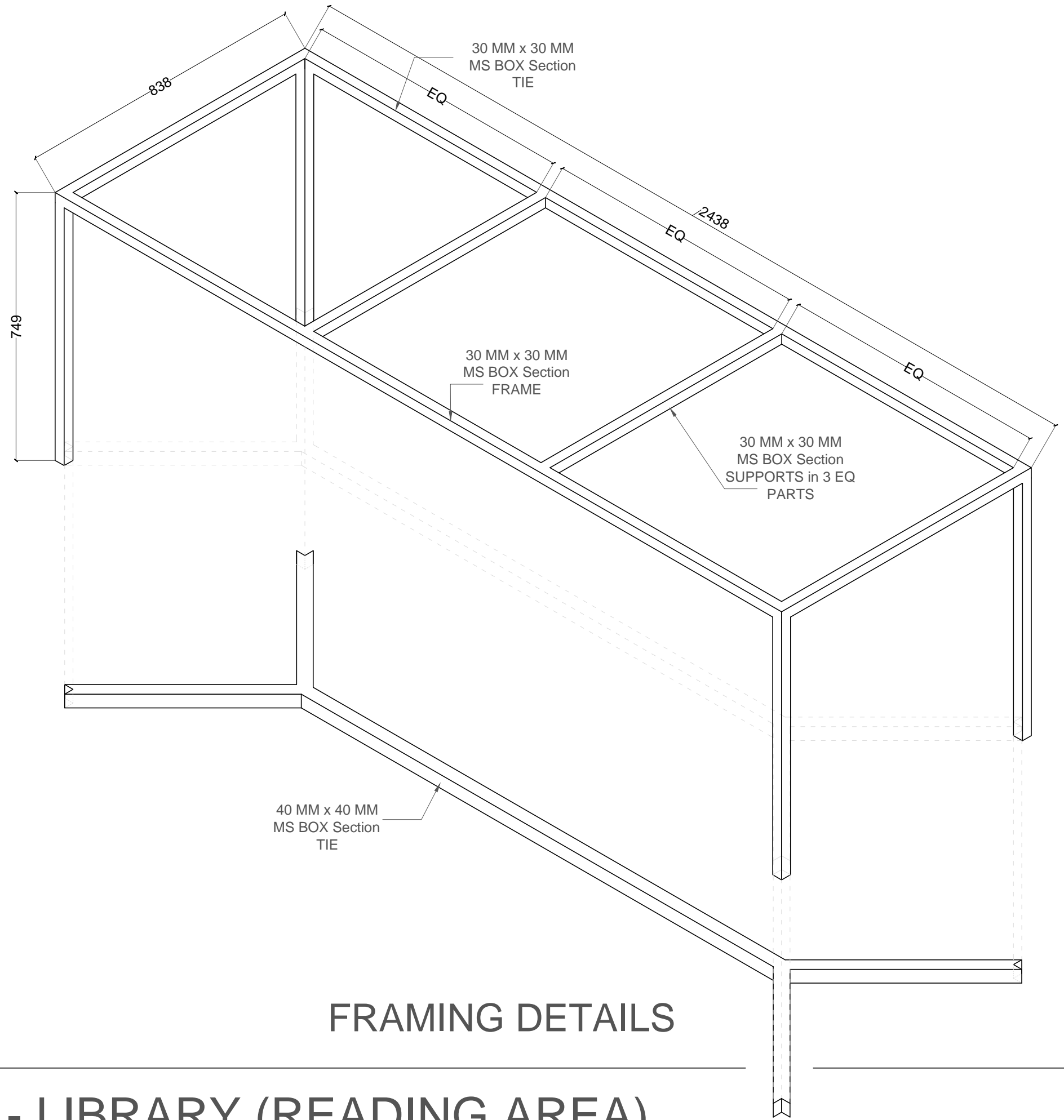

FRAMING DETAILS

TABLE DETAILS FOR - LIBRARY (READING AREA)

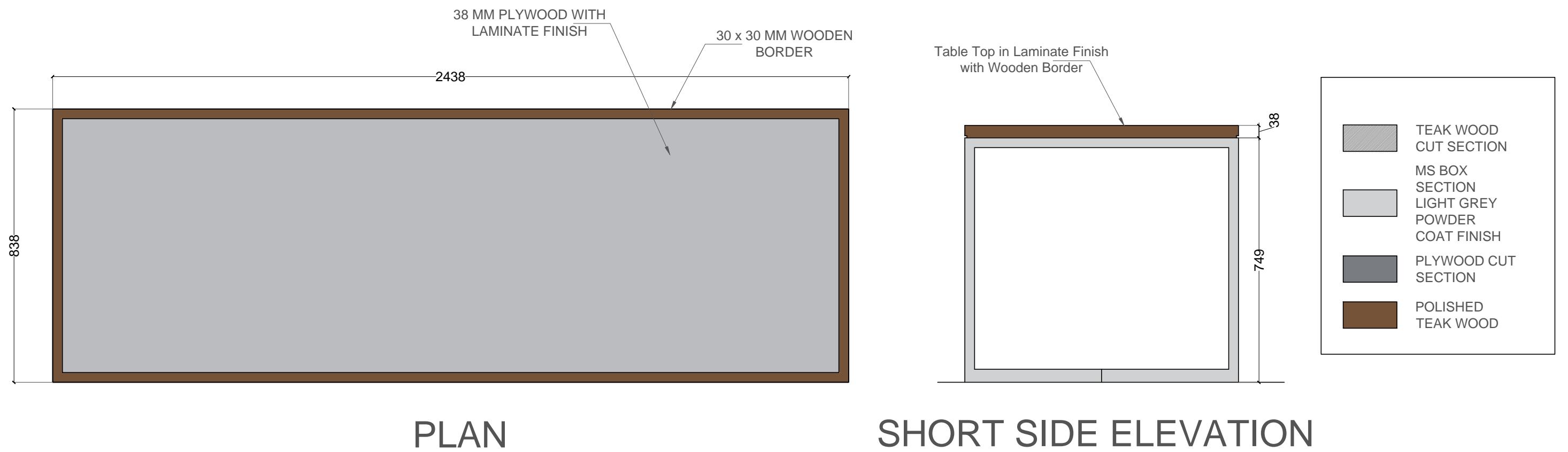
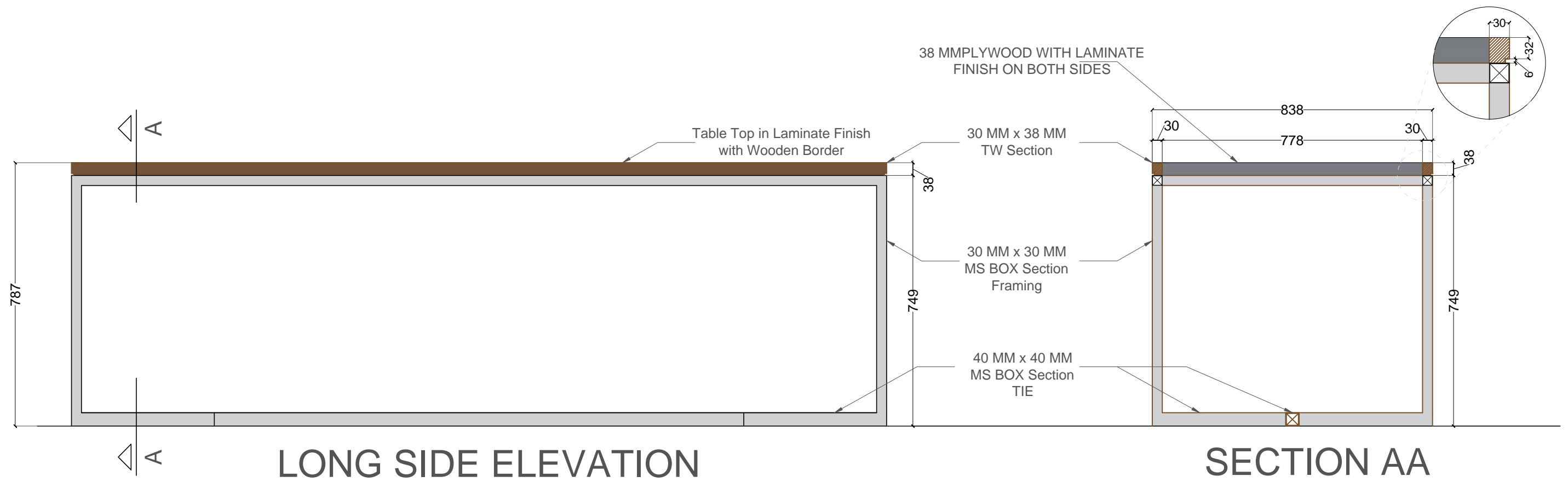
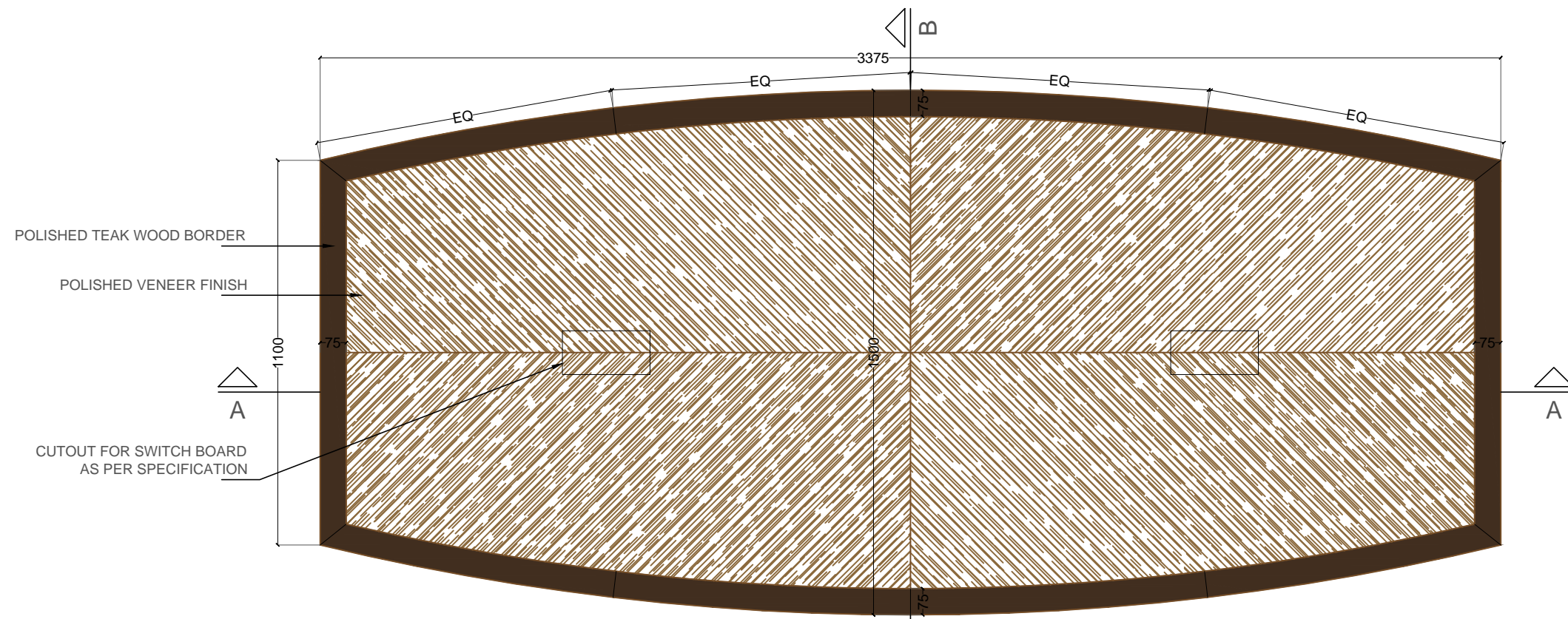
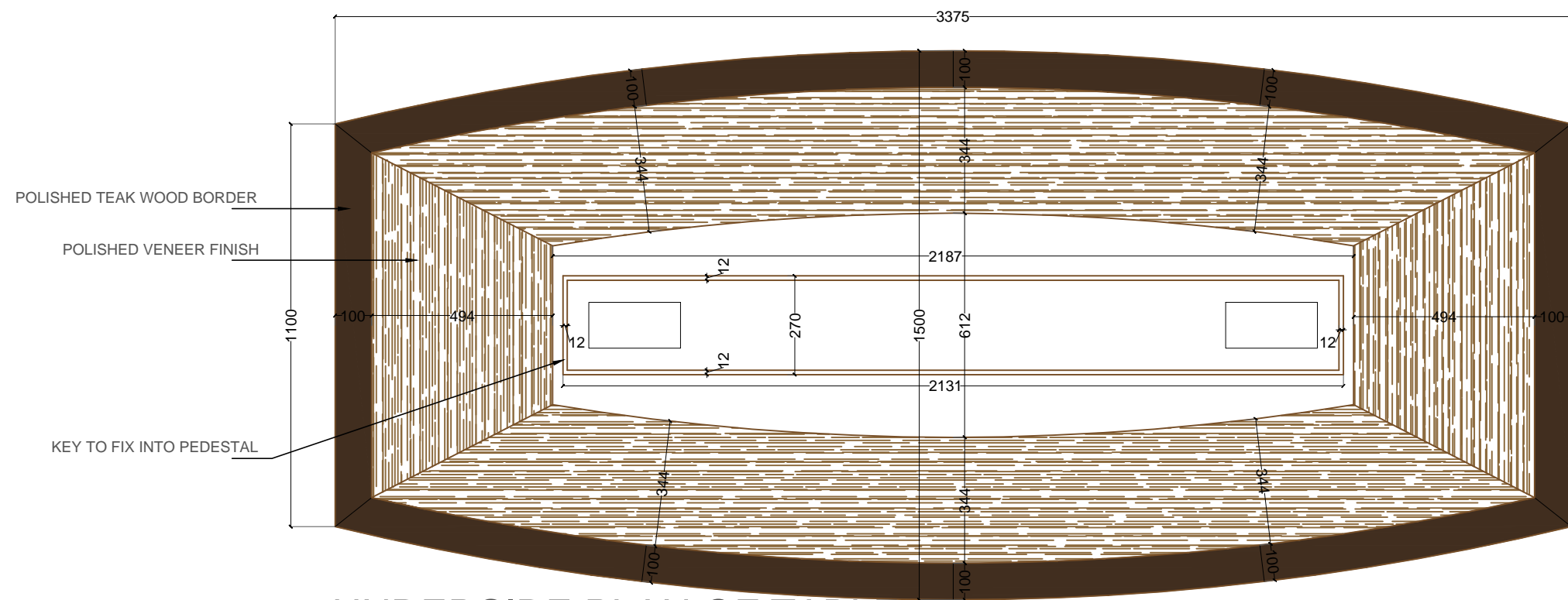

TABLE DETAILS FOR - LIBRARY (READING AREA)



PLAN



UNDERSIDE PLAN OF TABLE TOP

-  POLISHED TEAK WOOD
-  POLISHED VENEER
-  LAMINATE COLOR D

CONFERENCE TABLE DETAILS

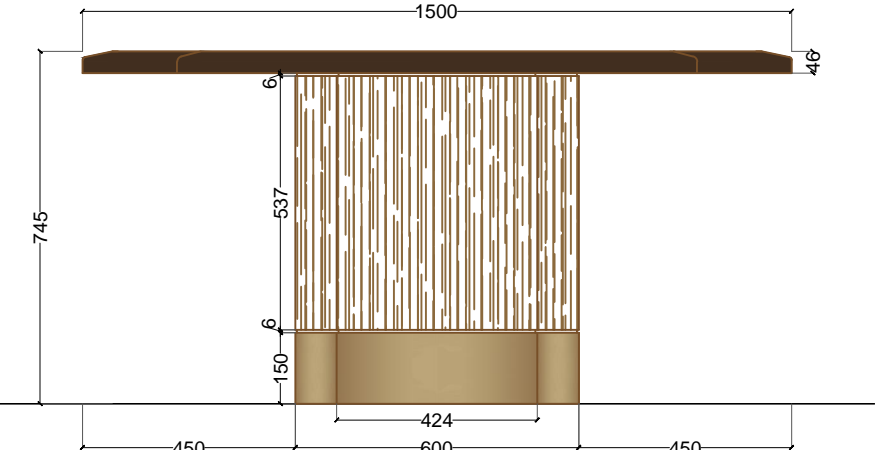
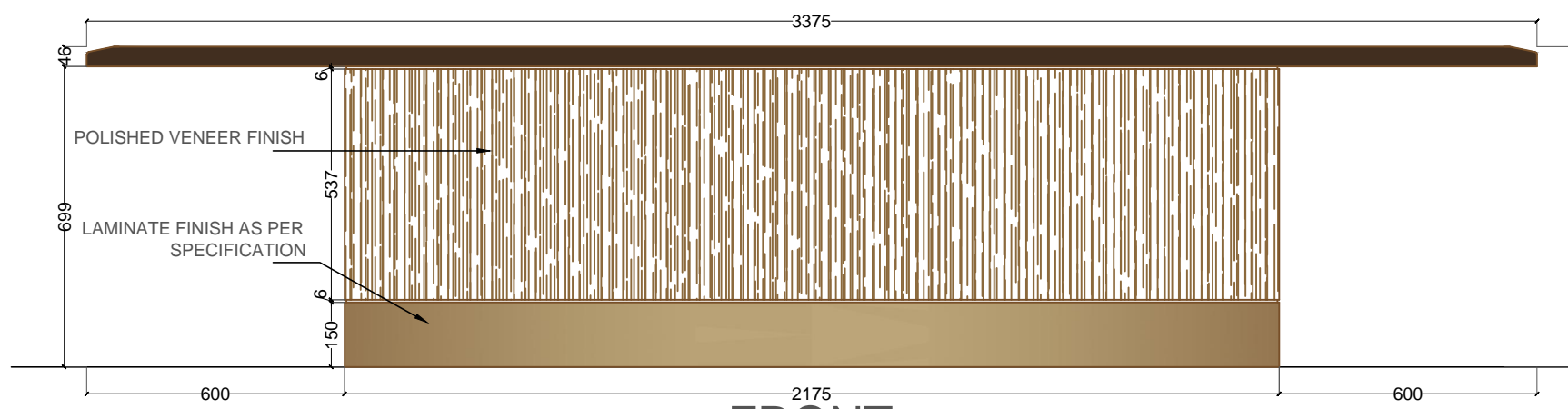
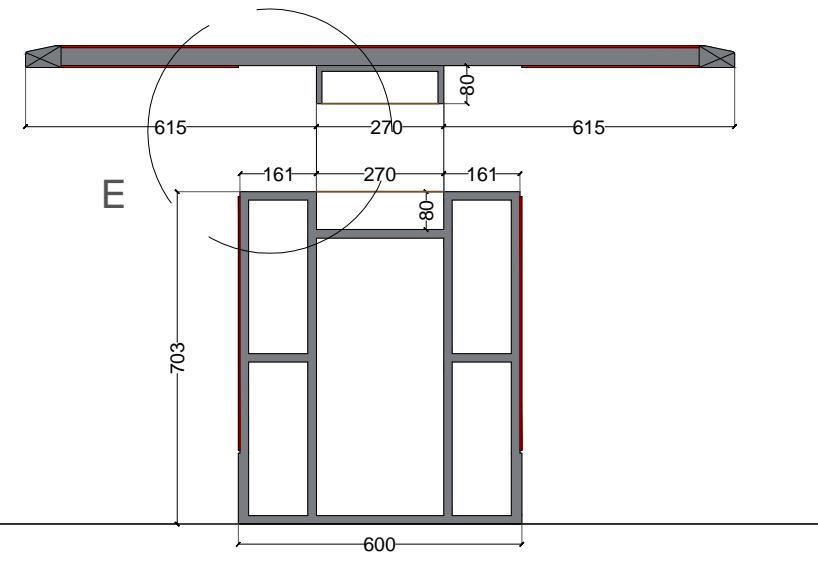
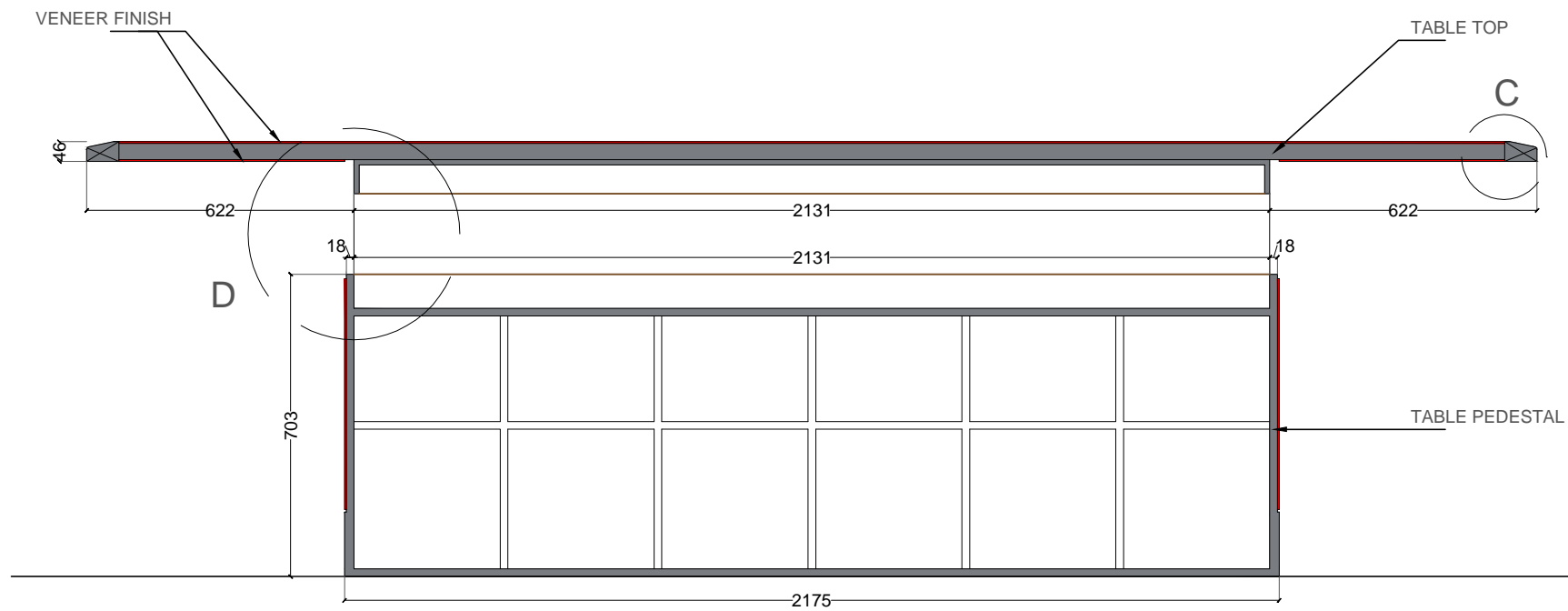

-  POLISHED TEAK WOOD
-  POLISHED VENEER
-  LAMINATE COLOR D

CONFERENCE TABLE DETAILS

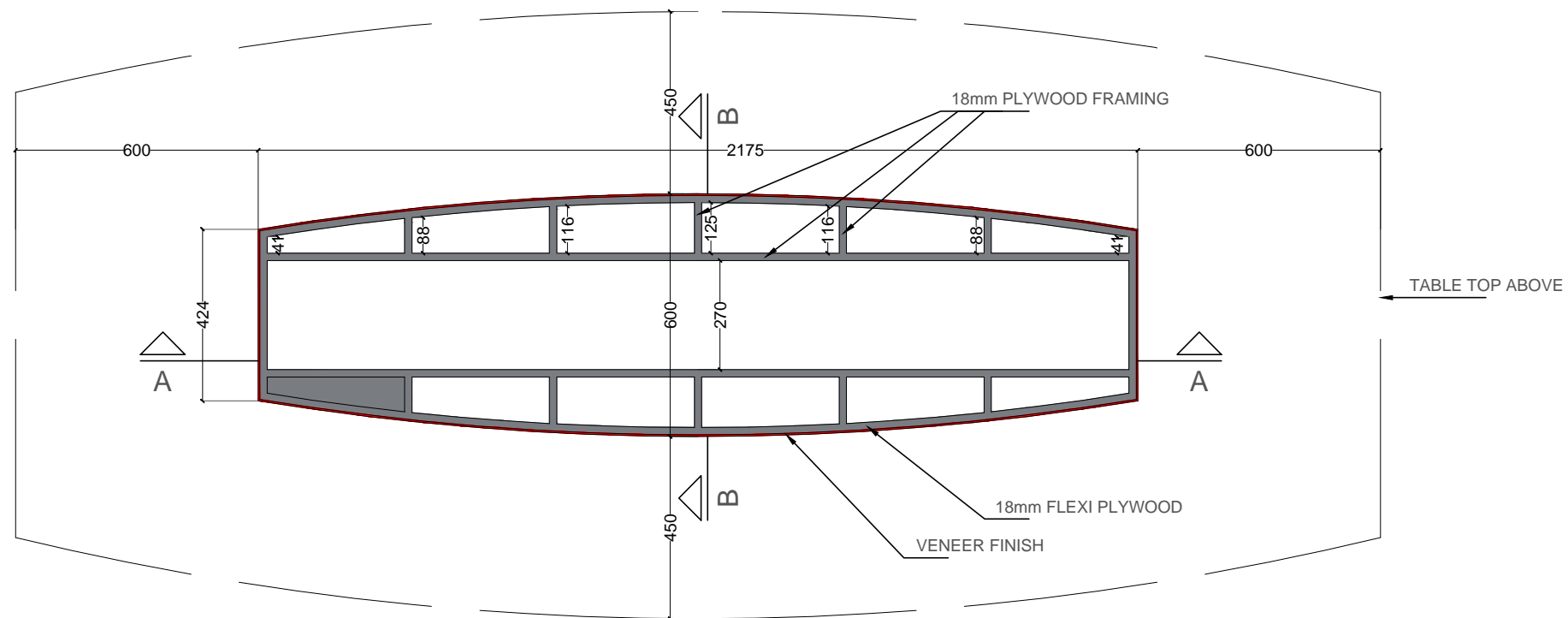
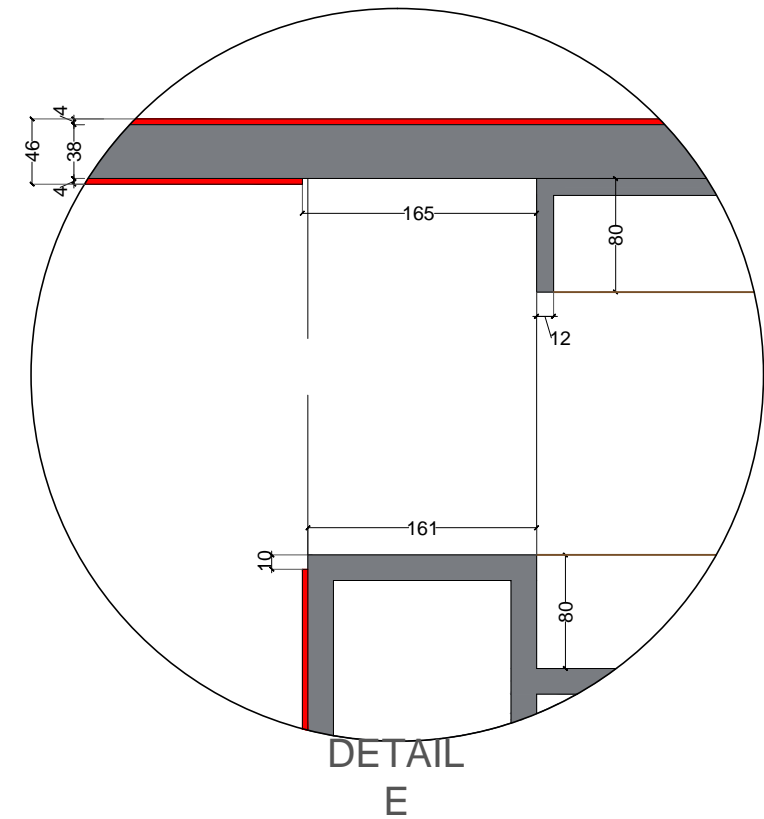
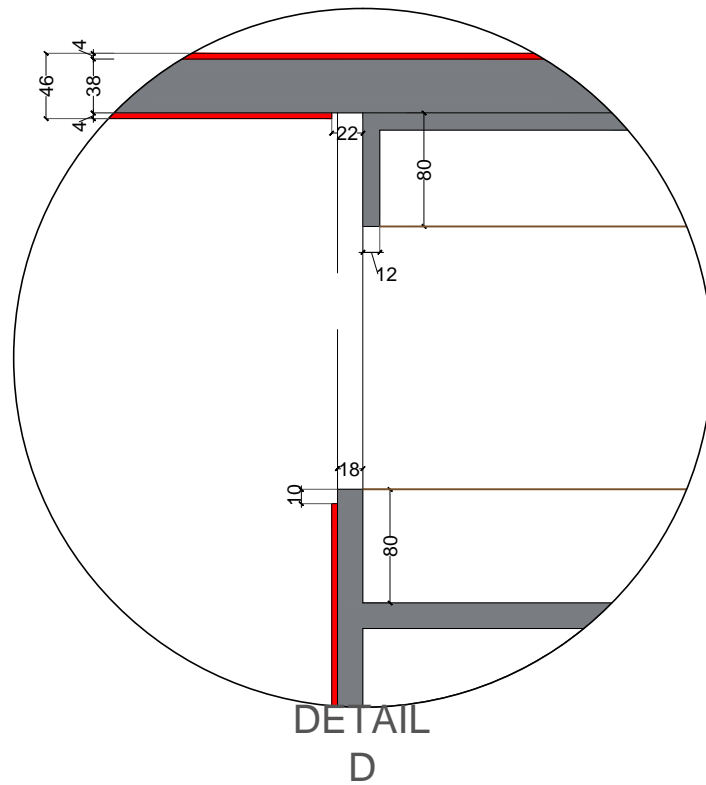
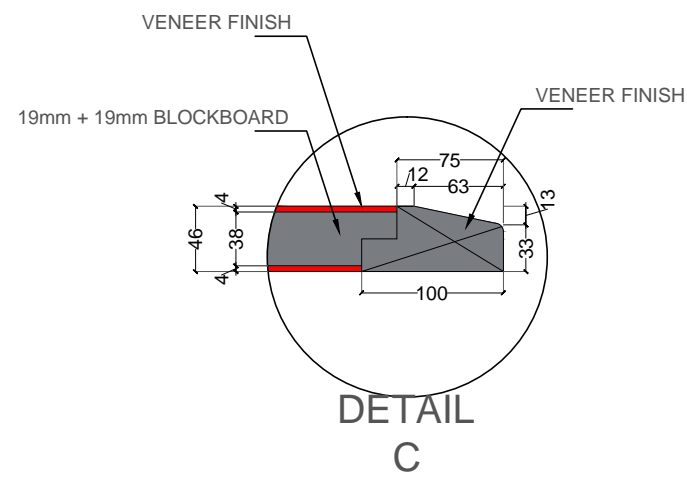

CONFERENCE TABLE DETAILS

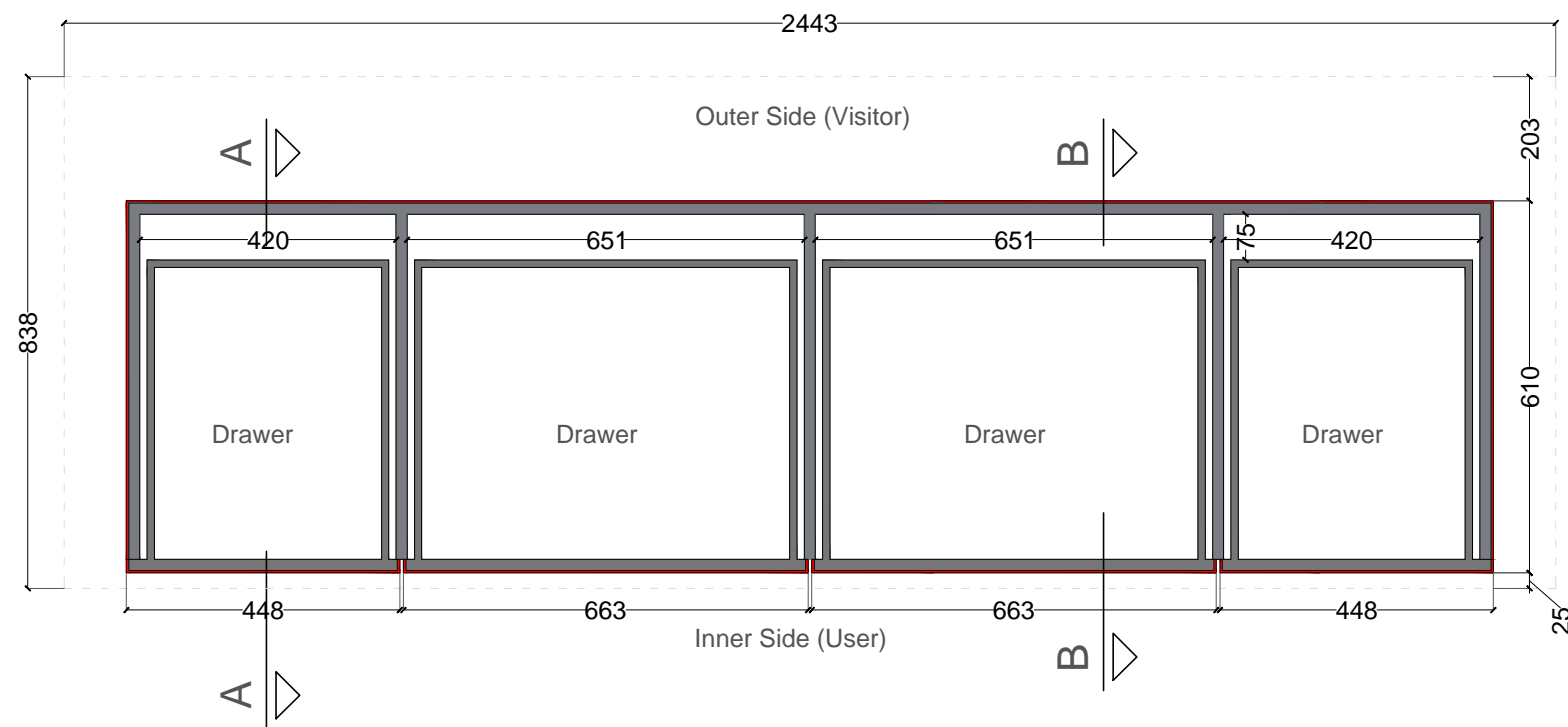

PLAN AT DRAWER LEVEL

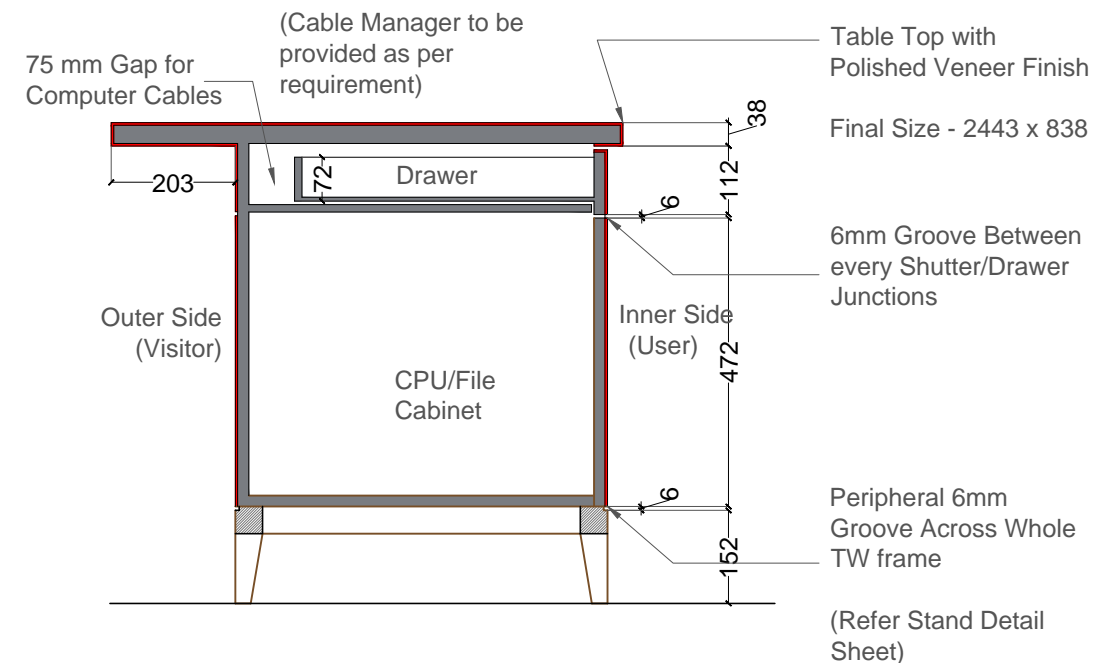

SECTION AA

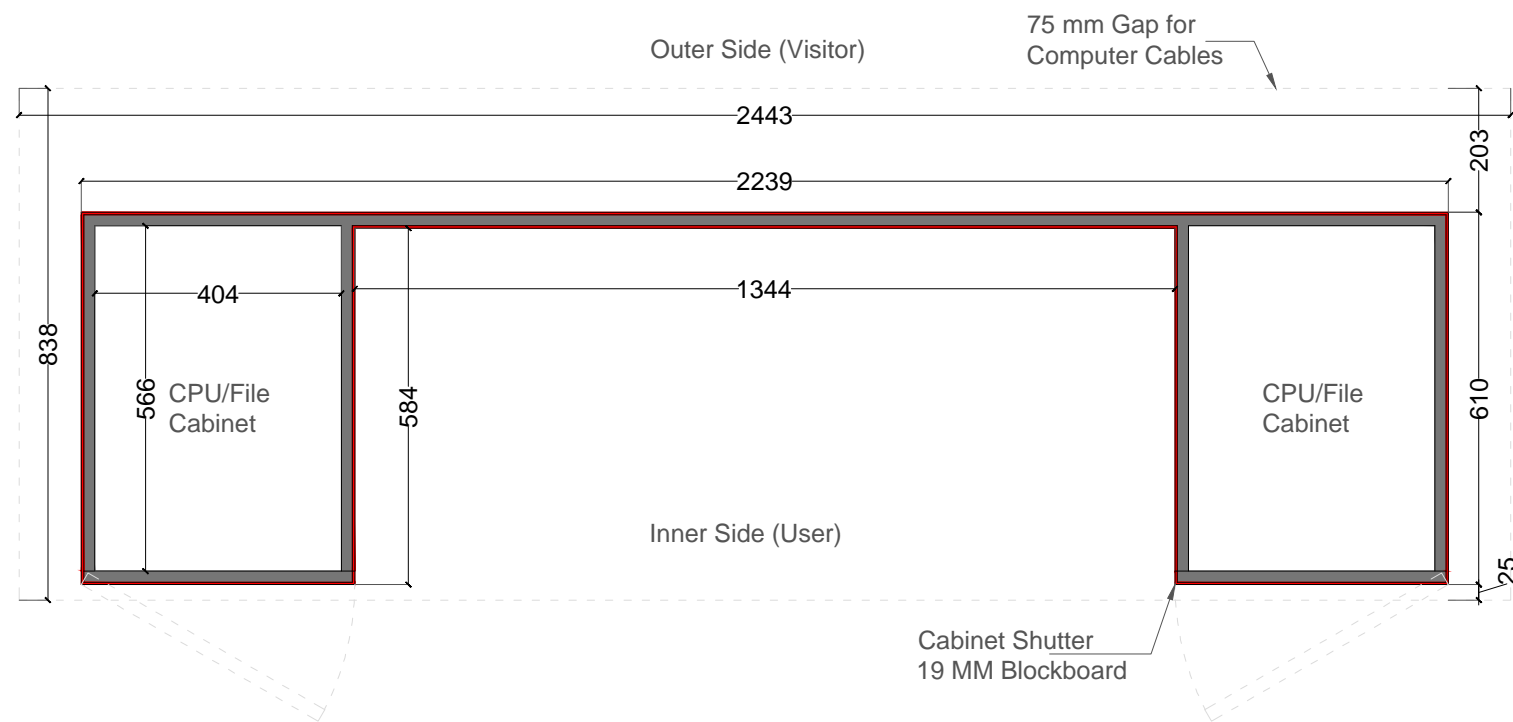

PLAN AT CABINET LEVEL

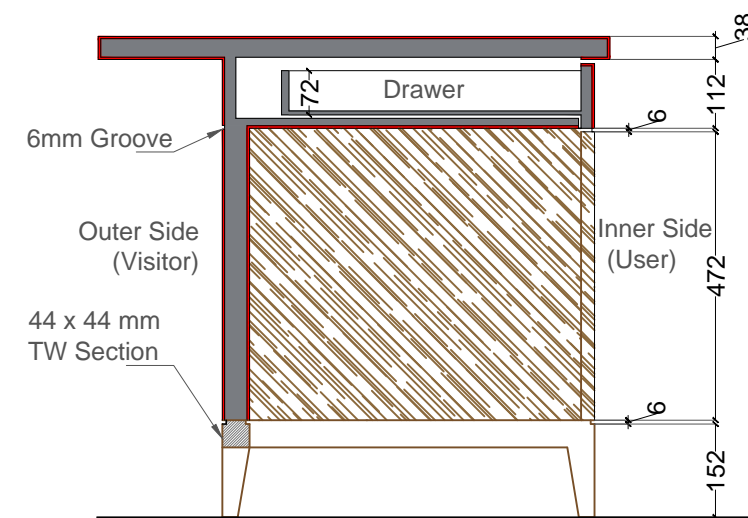

SECTION BB

GENERAL NOTES :-

* **EXTERNAL FINISH -**
4MM POLISHED VENEER
WITH MATTE FINISH
MELAMINE POLISH

* **INTERNAL FINISH -**
0.8 MM LAMINATE AS PER
SPECIFICATION

* Soft Close Telescopic
Channels for Drawers





-  POLISHED VENEER
-  TEAK WOOD CUT SECTION
-  4 MM VENEER CUT SECTION
-  PLYWOOD CUT SECTION
-  POLISHED TEAK WOOD

TABLE DETAILS FOR - PRINCIPAL & VICE PRINCIPAL'S CABIN

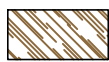
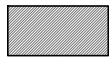

ELEVATION - In (User) Side

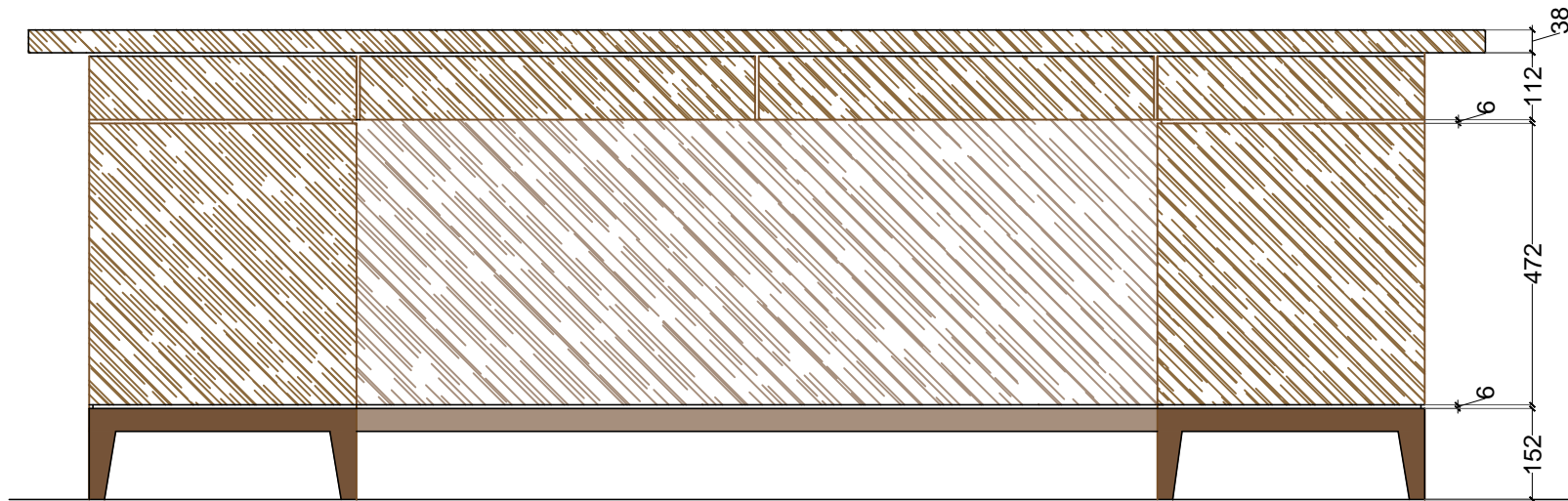
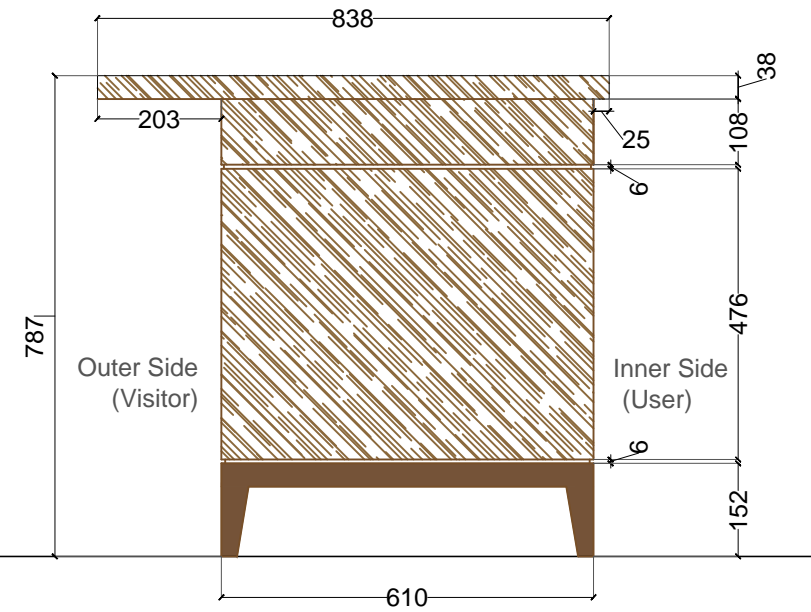

SIDE ELEVATION

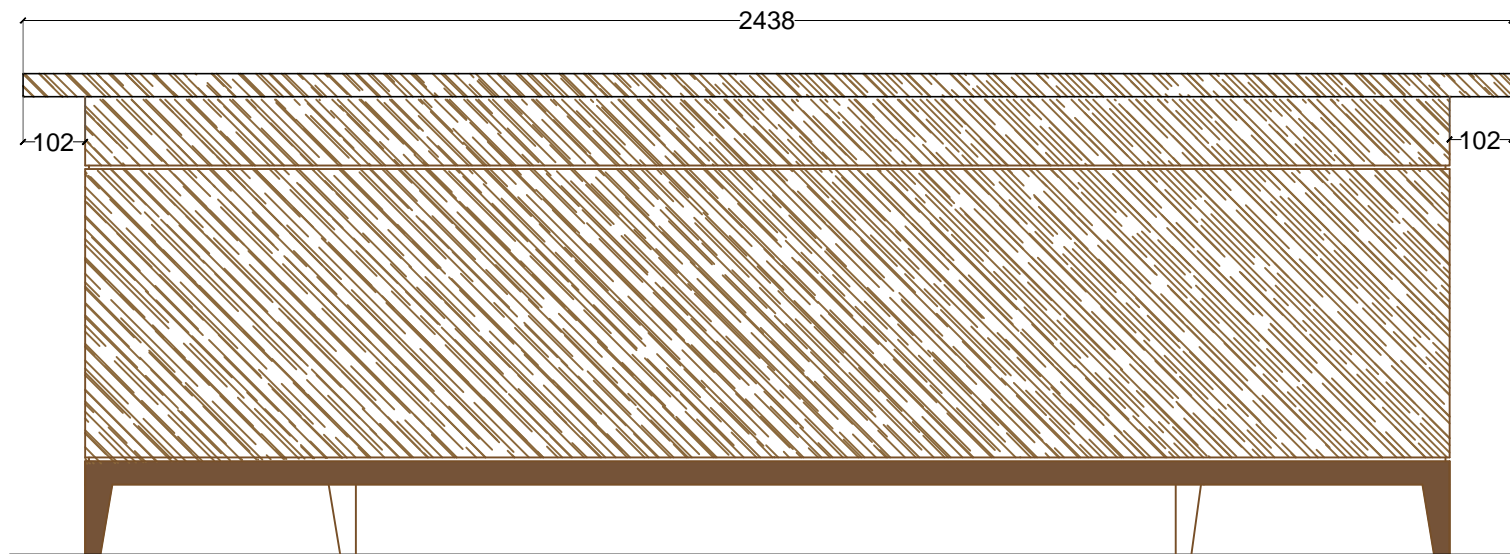

ELEVATION - Out (Visitor) Side

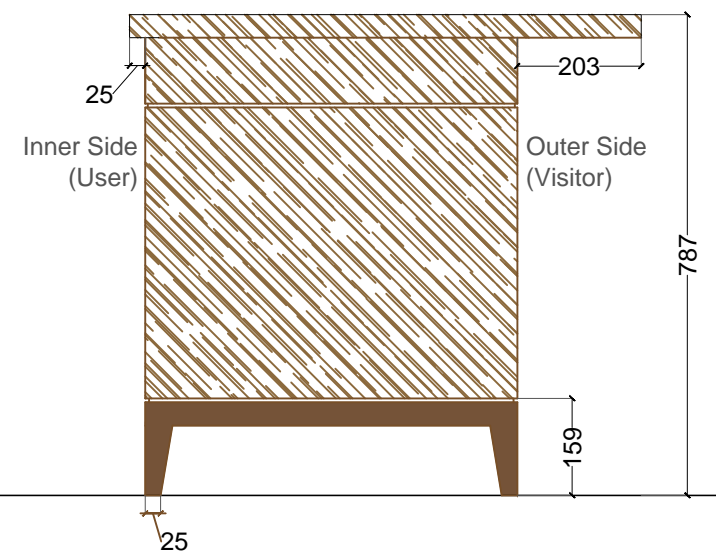

SIDE ELEVATION

GENERAL NOTES :-

* **EXTERNAL FINISH -**
4MM POLISHED VENEER
WITH MATTE FINISH
MELAMINE POLISH

* **INTERNAL FINISH -**
0.8 MM LAMINATE AS PER
SPECIFICATION

* Soft Close Telescopic
Channels for Drawers

-  POLISHED VENEER
-  TEAK WOOD CUT SECTION
-  4 MM VENEER CUT SECTION
-  PLYWOOD CUT SECTION
-  POLISHED TEAK WOOD

TABLE DETAILS FOR - PRINCIPAL & VICE PRINCIPAL'S CABIN

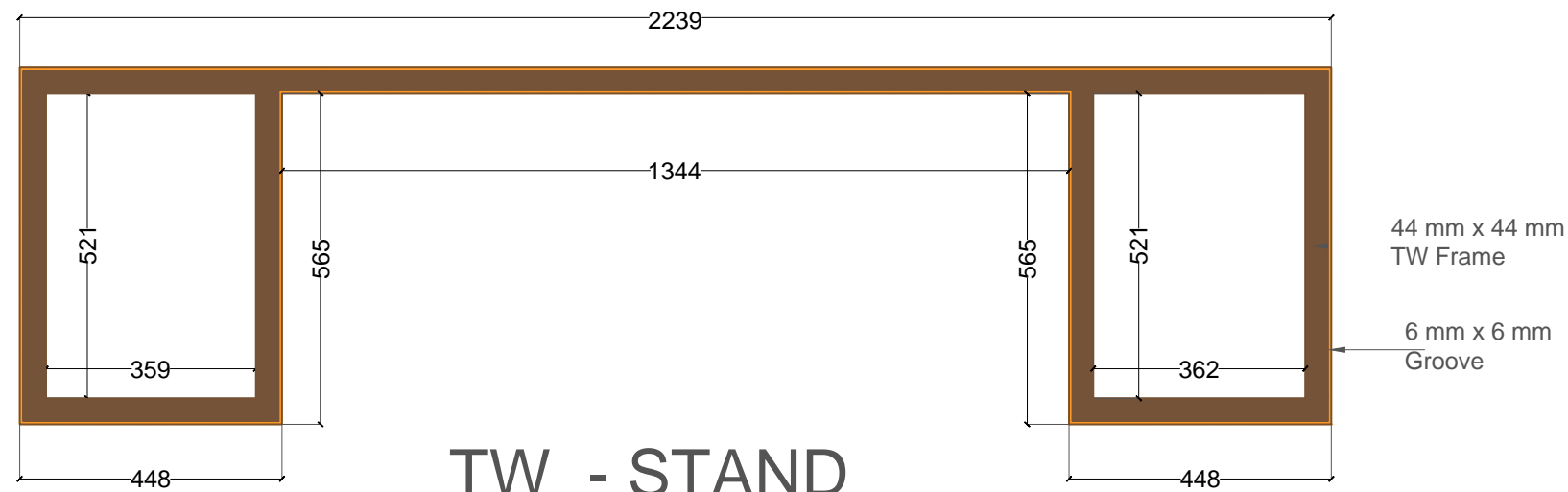

TW - STAND
PLAN For 6 mm x 6 mm Groove

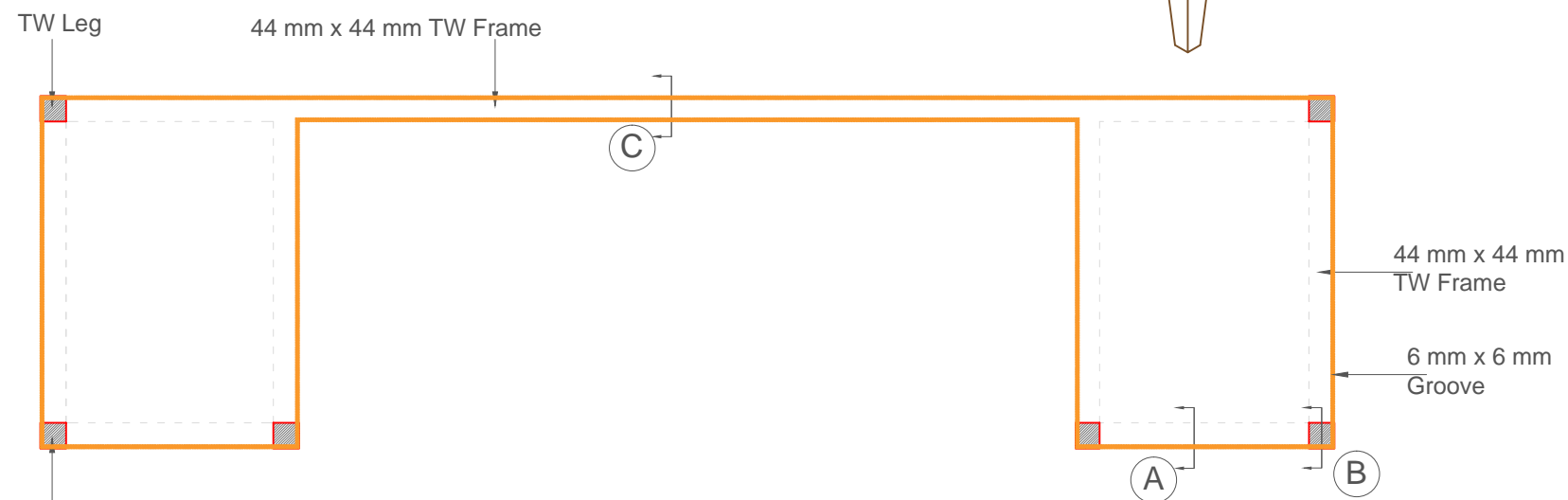
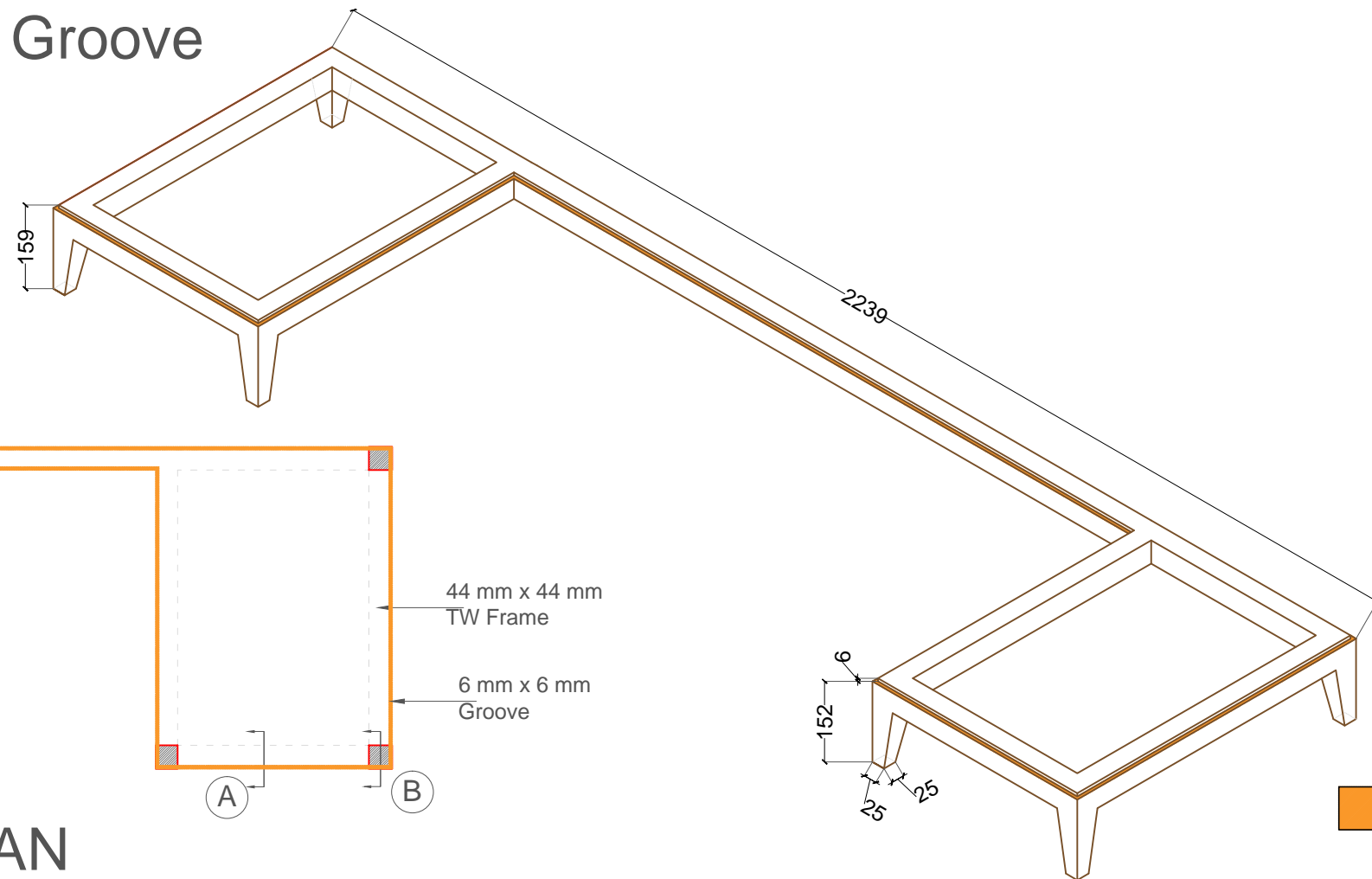
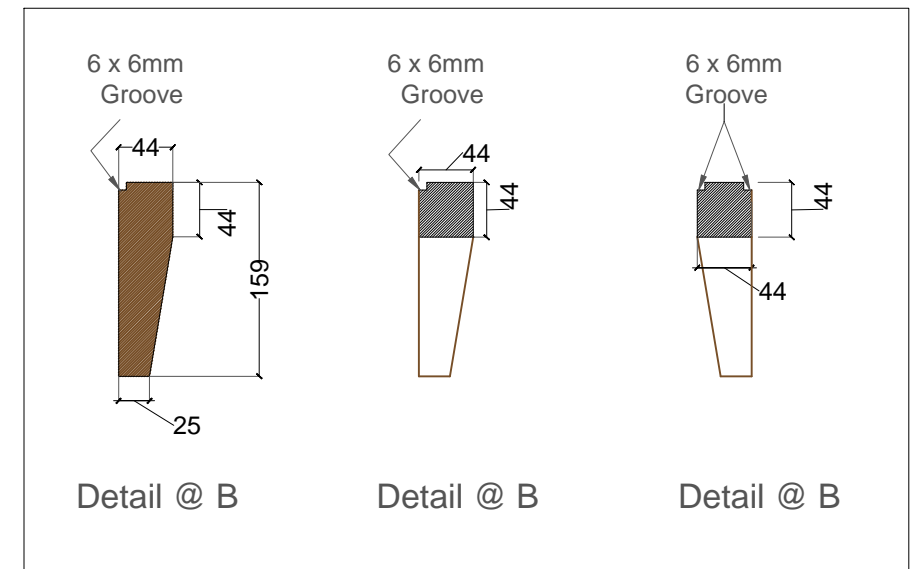

TW STAND - PLAN
(FOR LEGS LOCATIONS)

- 6 x 6 MM GROOVE THROUGHOUT EXTERNAL PERIPHERY
- TEAK WOOD CUT SECTION
- POLISHED TEAK WOOD

TABLE DETAILS FOR - PRINCIPAL & VICE PRINCIPAL'S CABIN

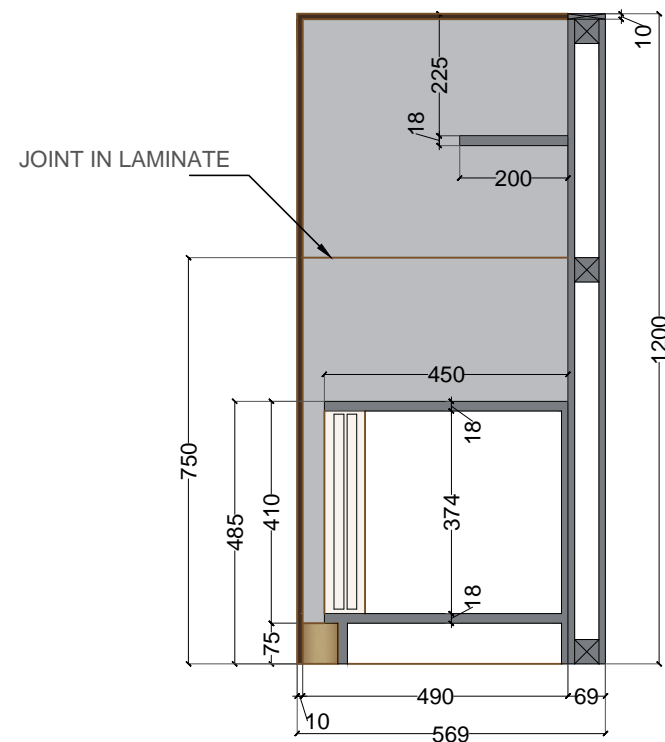

SECTIONAL ELEVATION A

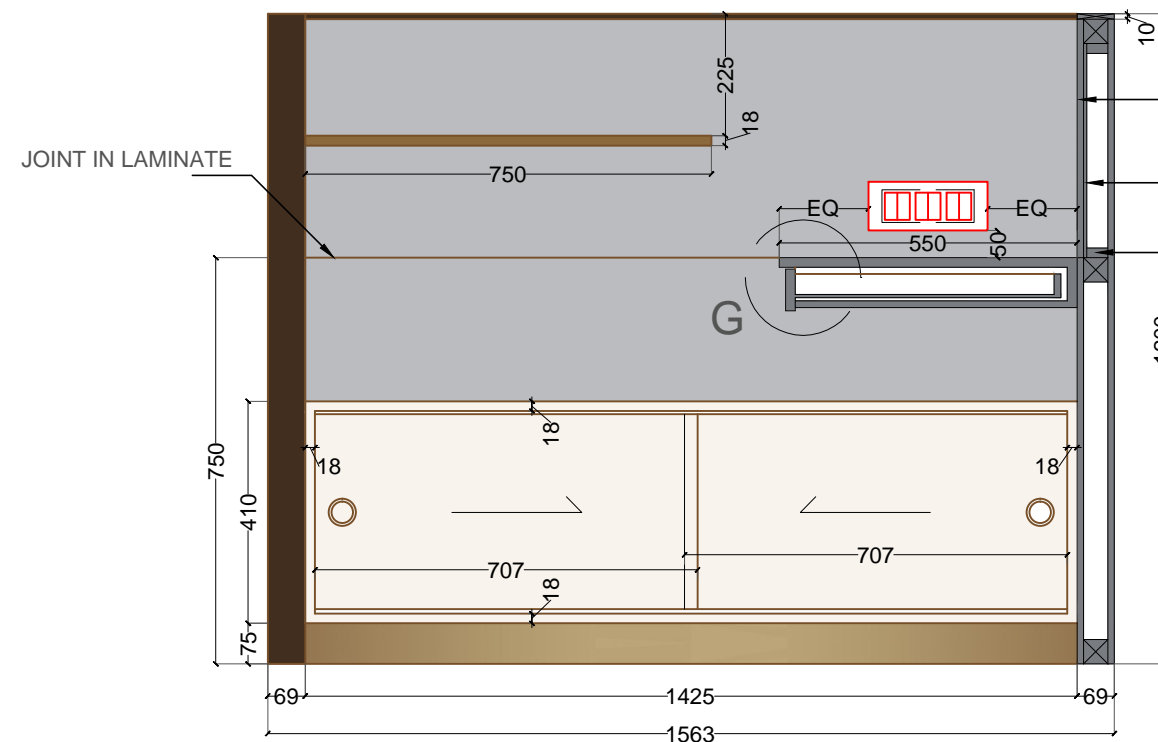
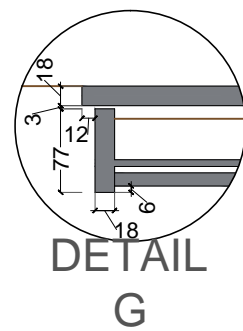

SECTIONAL ELEVATION B

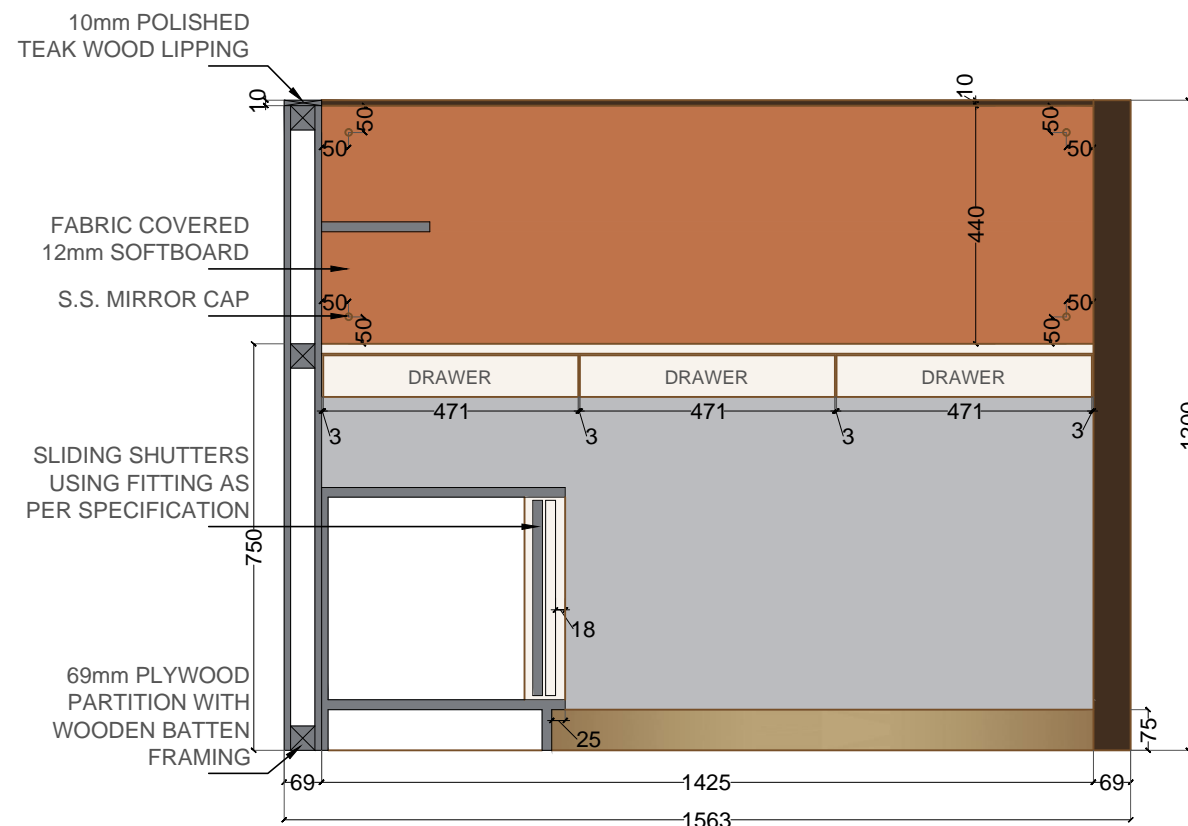

SECTIONAL ELEVATION C

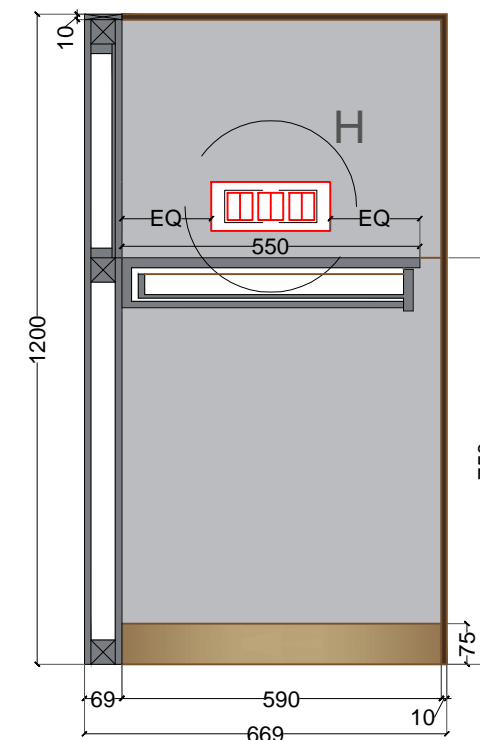
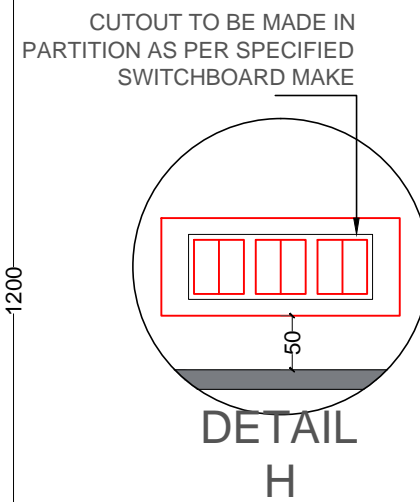

SECTIONAL ELEVATION D

- | | |
|--|--------------------|
| | LAMINATE COLOR A |
| | LAMINATE COLOR B |
| | LAMINATE COLOR C |
| | LAMINATE COLOR D |
| | FABRIC |
| | POLISHED TEAK WOOD |

TABLE DETAILS FOR - CUBICLES (STAFF ROOM)

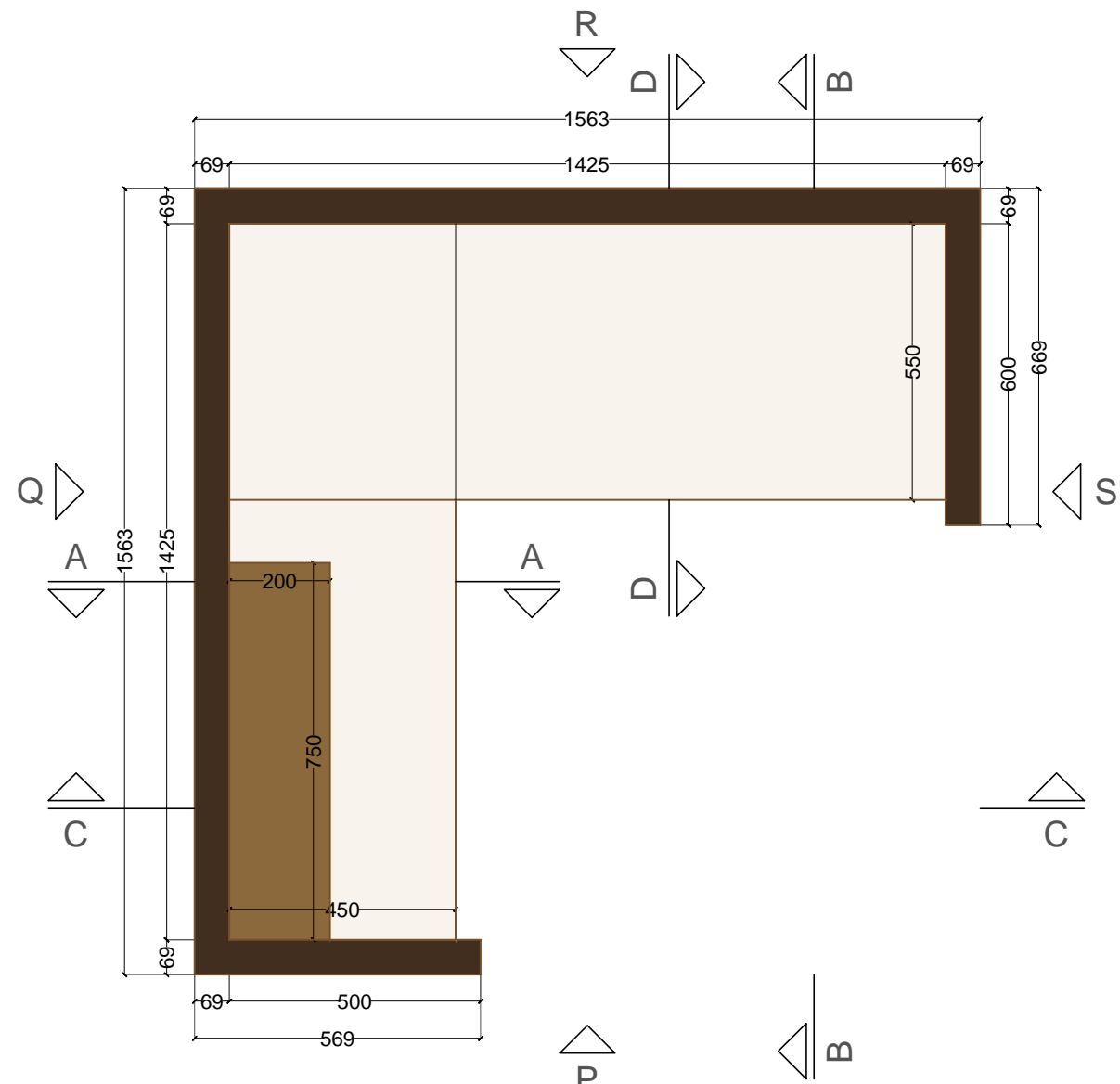

PLAN

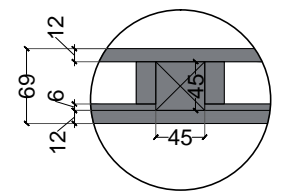

DETAIL F

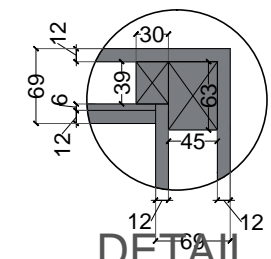

DETAIL E

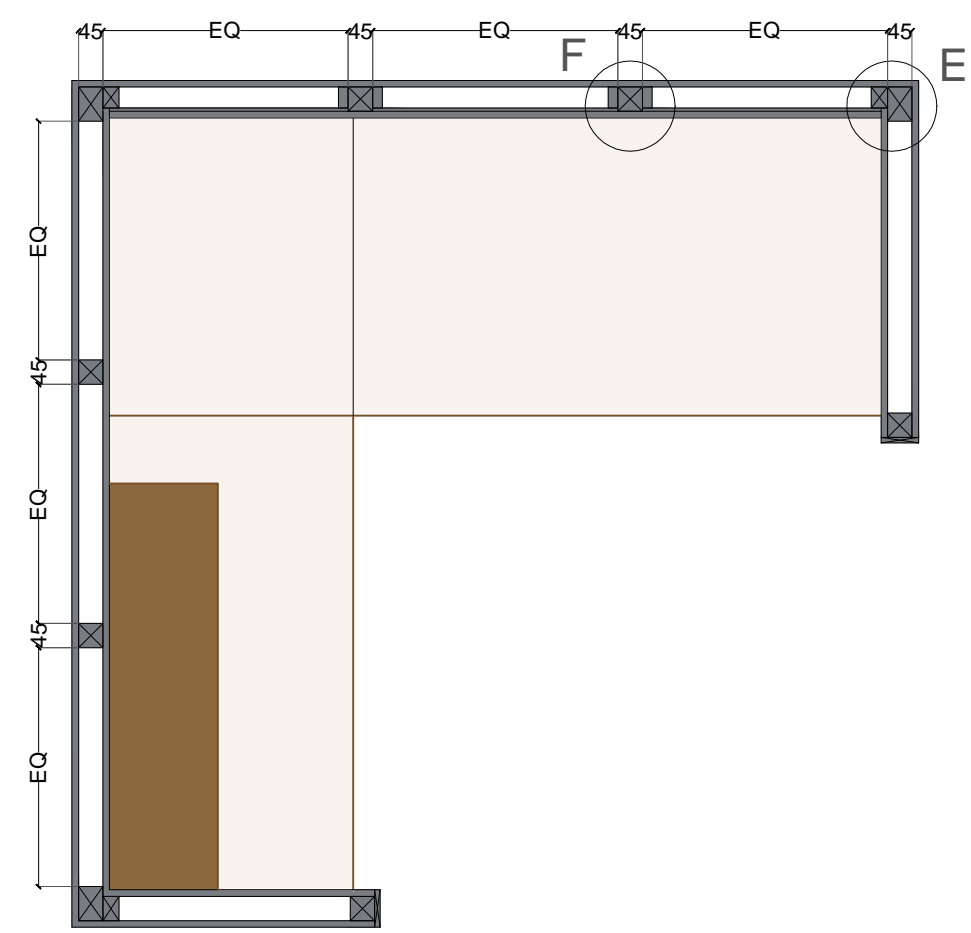

PLAN SHOWING PARTITION DETAILS







-  LAMINATE COLOR A
-  LAMINATE COLOR B
-  LAMINATE COLOR C
-  LAMINATE COLOR D
-  FABRIC
-  POLISHED TEAK WOOD

TABLE DETAILS FOR - CUBICLES (STAFF ROOM)





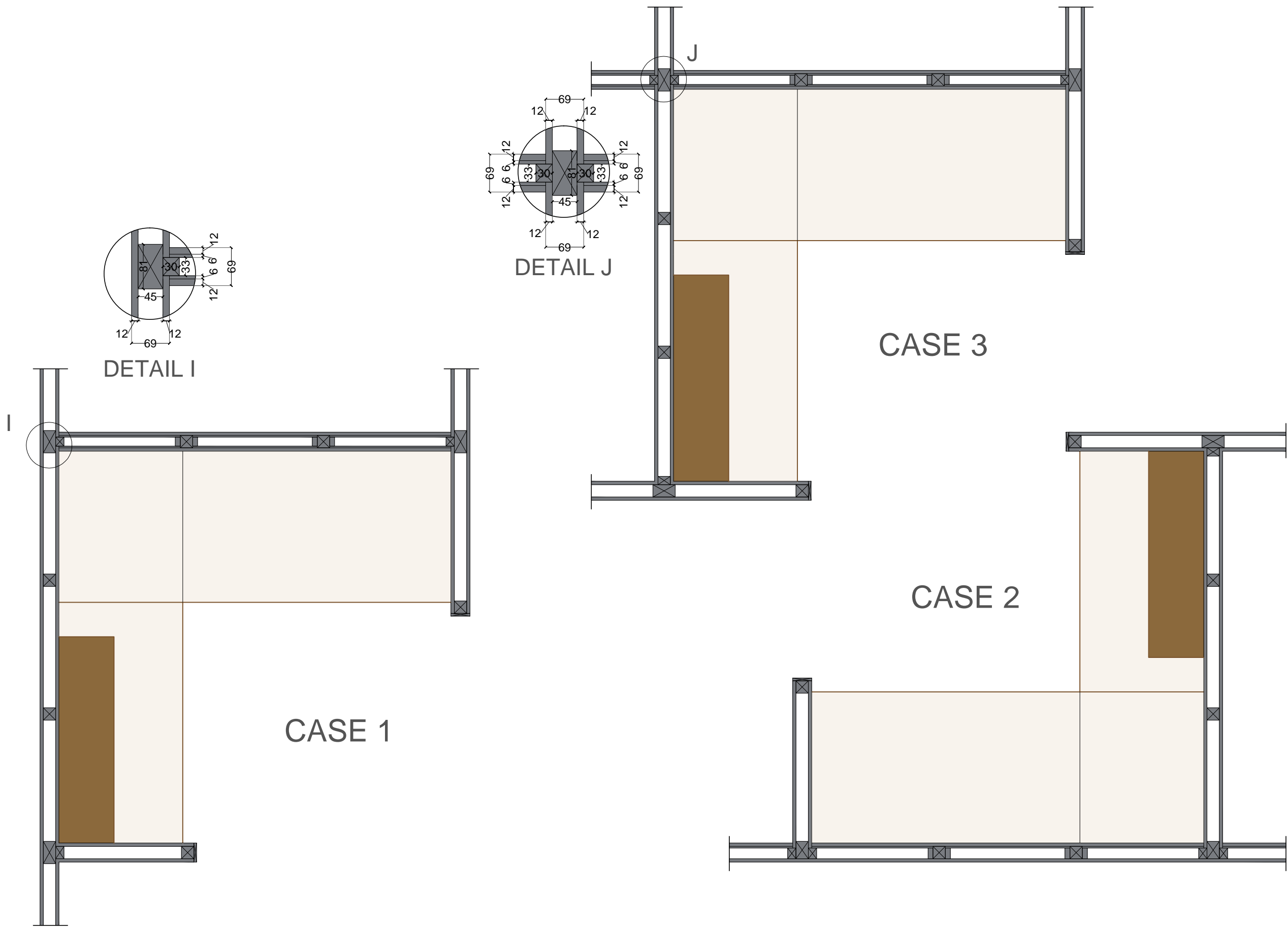

-  LAMINATE COLOR A
-  LAMINATE COLOR B
-  LAMINATE COLOR C
-  LAMINATE COLOR D
-  FABRIC
-  POLISHED TEAK WOOD

TABLE DETAILS FOR - CUBICLES (STAFF ROOM)



ELEVATION P WRT CASE 2

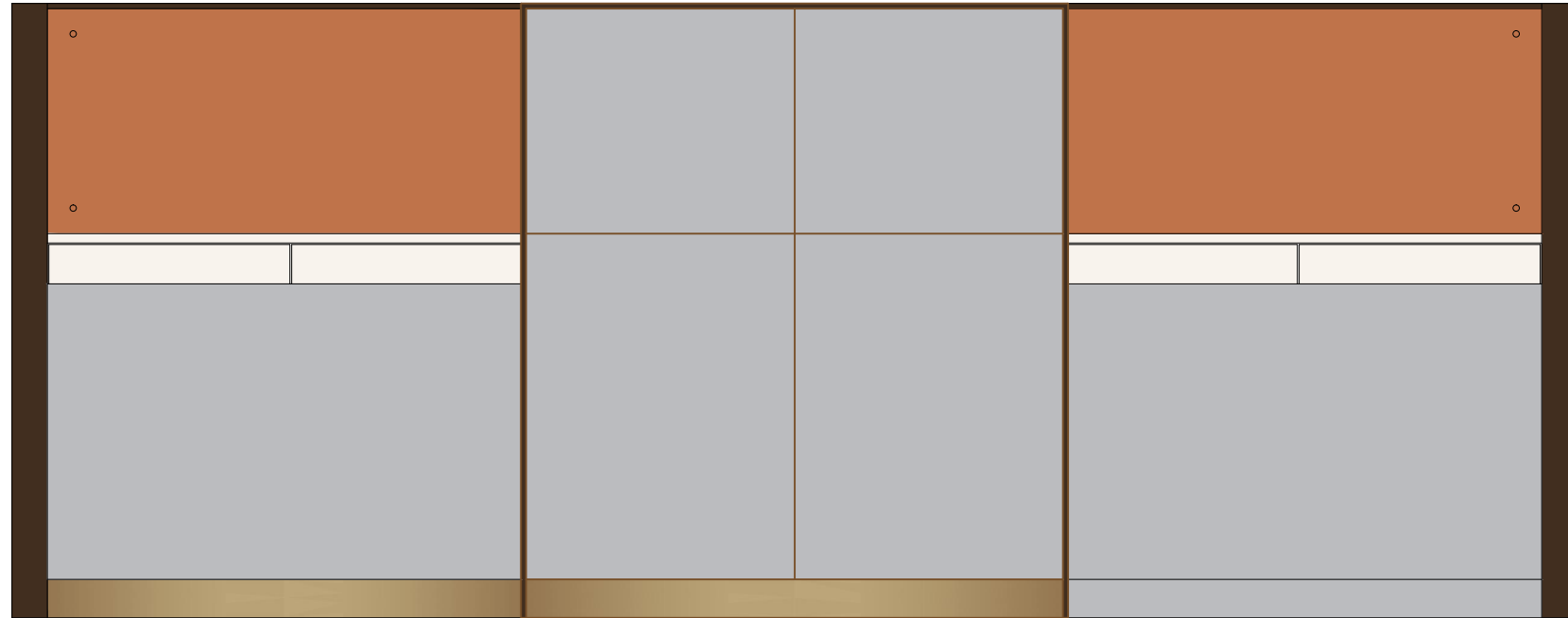
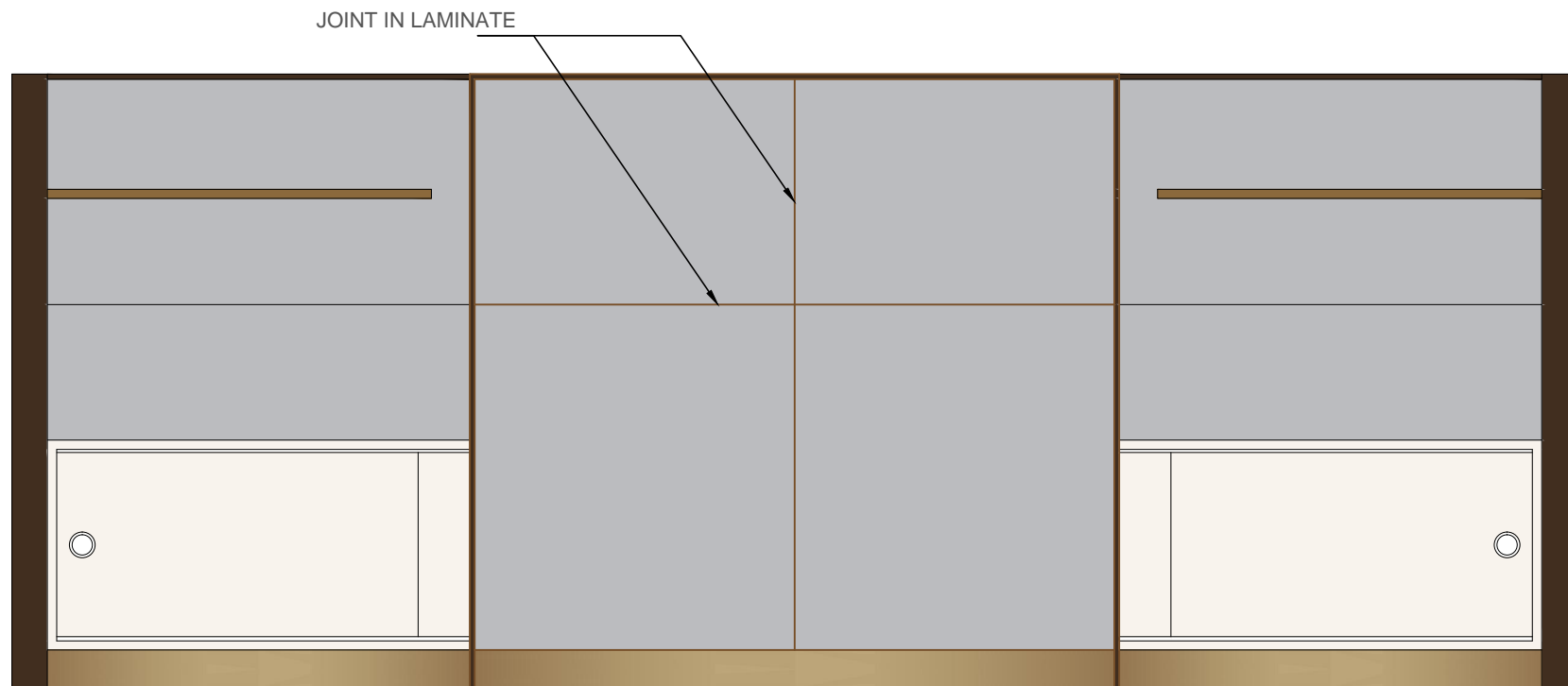

JOINT IN LAMINATE

- LAMINATE COLOR A
- LAMINATE COLOR B
- LAMINATE COLOR C
- LAMINATE COLOR D
- FABRIC
- POLISHED TEAK WOOD

ELEVATION S WRT CASE 1

TABLE DETAILS FOR - CUBICLES (STAFF ROOM)

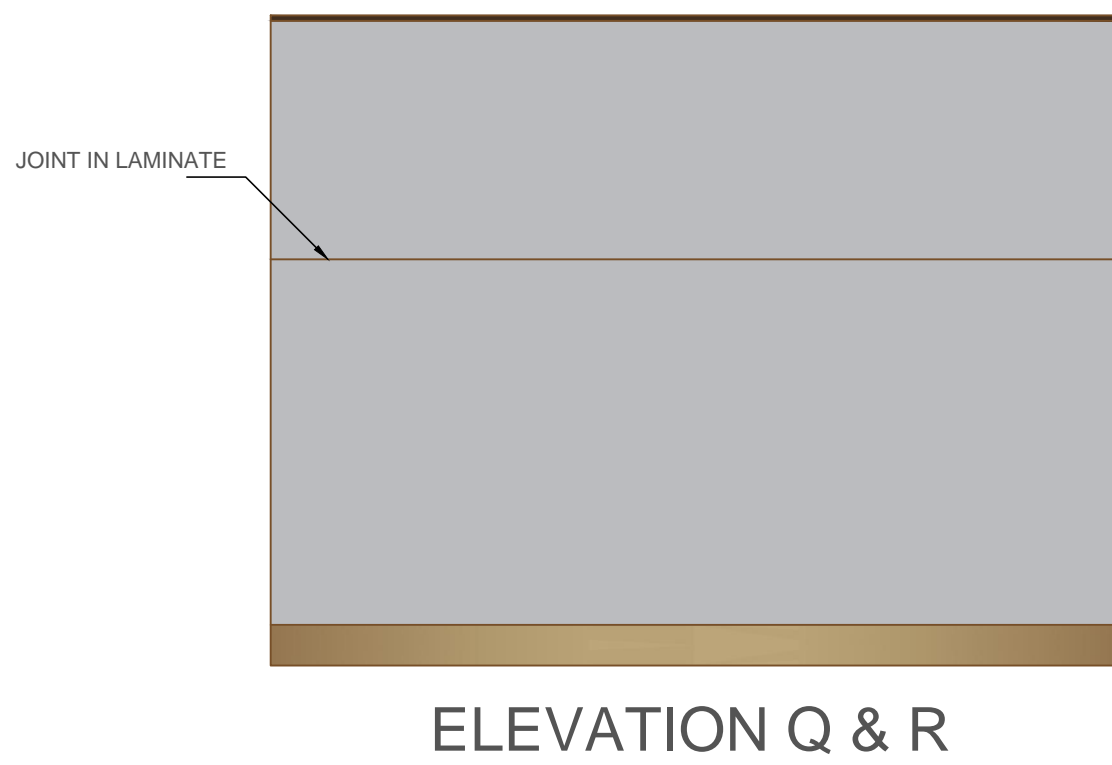
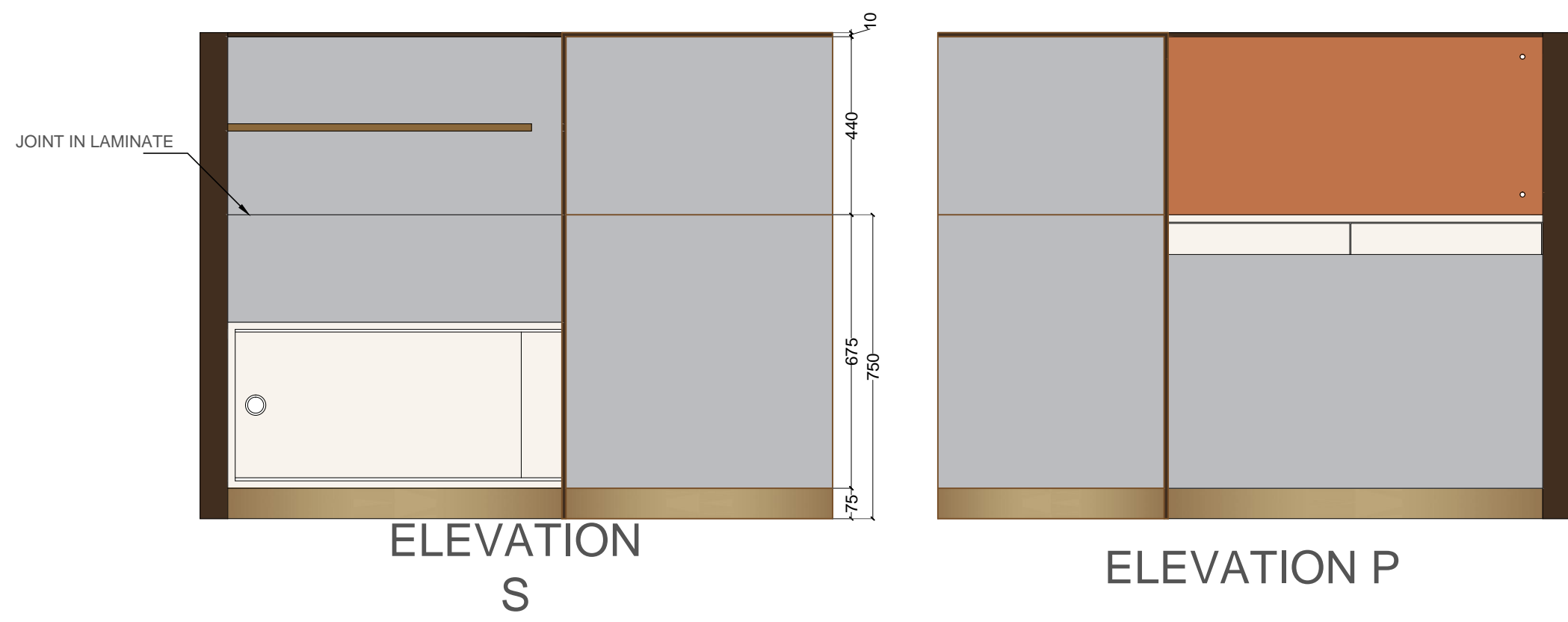

- LAMINATE COLOR A
- LAMINATE COLOR B
- LAMINATE COLOR C
- LAMINATE COLOR D
- FABRIC
- POLISHED TEAK WOOD

TABLE DETAILS FOR - CUBICLES (STAFF ROOM)